

MS-XXXX-3458-XX

DATE	LET	REVISIONS	CD	MAN	CK	APP
		Added key-in wetting current control P. L'Enfant, 20th October 2000				
		Moved column position pot circuits from column PWB to interface PWB P. L'Enfant, 11th December 2000				
		PWB changed due to panel length change M. Lansley, November 2001				
		X355 Update Changed SPARE_DIGITAL_IN_2 to BRAKE_PAD_SENSOR. Added R310, the BRAKE_PAD_WEAR_SENSOR_OFFSET_RESISTOR P. Wood, July 2003				
		X355 Update Moved R310, the BRAKE_PAD_WEAR_OFFSET_RESISTOR to MISCELL_INPUTS (sheet 9) Updated the following connections: J3-21 now becomes BRAKE_PAD_SENSOR J1-22 now becomes BRAKE_PAD_RETURN J1-11 now becomes AUTOLAMP_SENSOR P. Wood, Sept 2003				

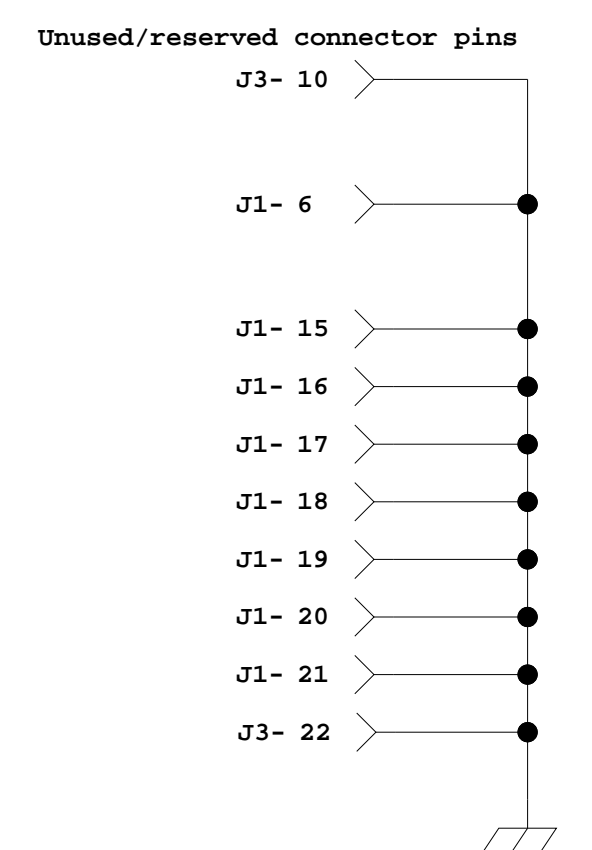
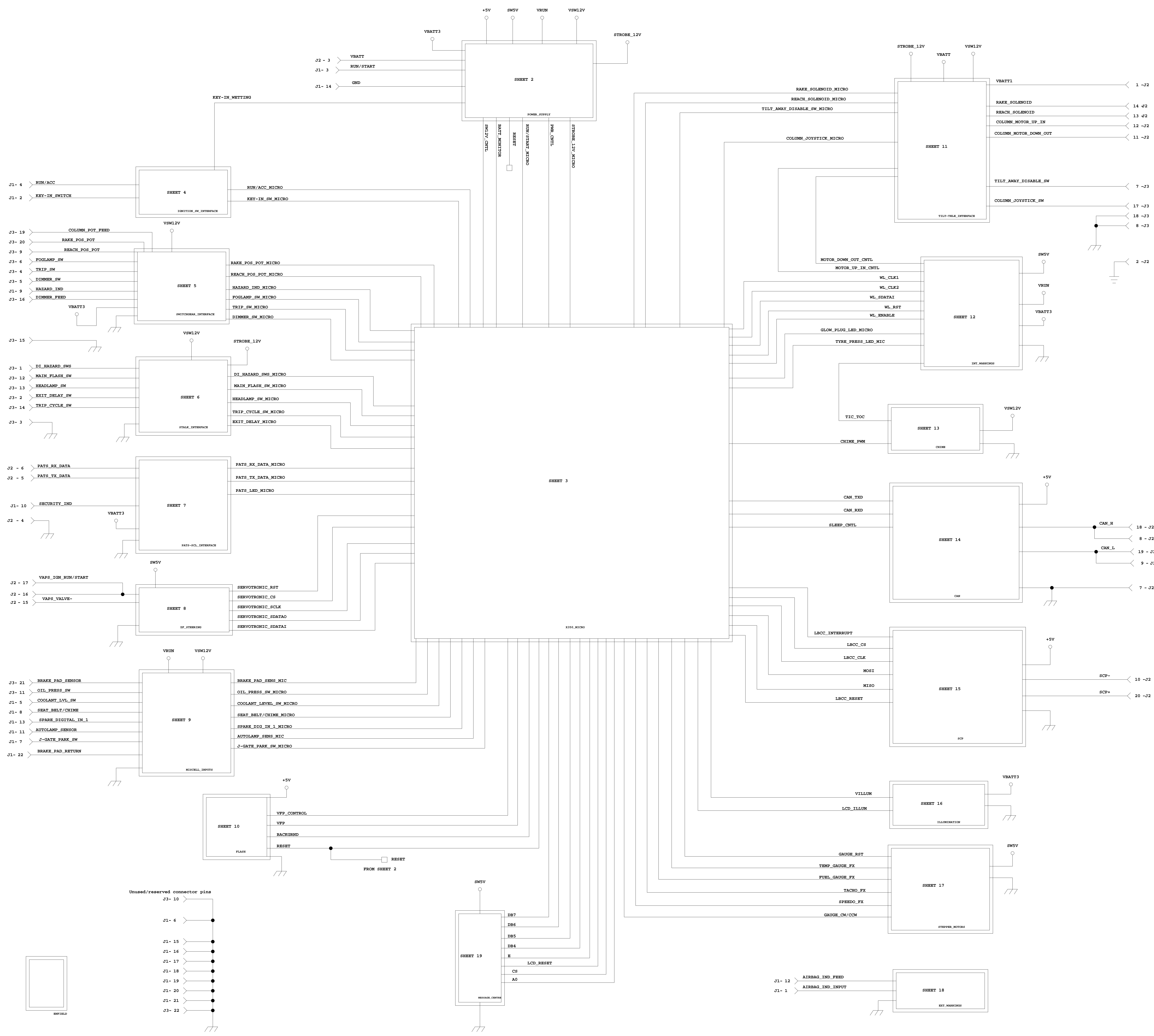

PART MUST COMPLY WITH SPECIFICATION MS-8999999-01 TO HELP ASSURE HEALTH, SAFETY AND THE ENVIRONMENT

Visteon PROJECT ENGINEERING

COMPUTER MANUAL "E" SIZE

CD COLUMN = GRAPHIC DATA LEVEL ORIGINAL WHEN RED

DO NOT SCALE ABOVE SCALE FOR REFERENCE ONLY

REP	PROJECT/SCH/SCH NAME	DATE	CHECKED	SCALE	APPROVED
		SEPT03	K. GREEN	NONE	M. LANSLEY

UNLESS OTHERWISE SPECIFIED:
DIMENSIONS ARE IN MILLIMETERS
HATCHED DIM. +/- ANGULAR DIM. +/-

MATERIAL: PWB_NUMBER=12418

NAME: SKETCH - WIRING DIAGRAM LOGIC

NO. MS-XXXX-3458-XX

PLANT CODE:

X355 TOP LEVEL "LOGIC" PWB12418 :- ISSUE 1_2

ENFIELD MECHANICAL DETAIL

MOTHERPANEL DETAIL

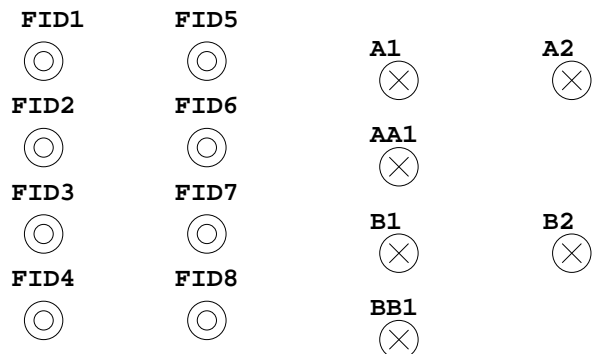

DAUGHTER BOARD DETAIL

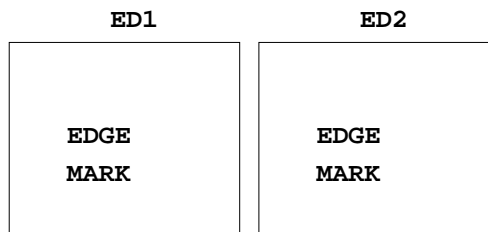
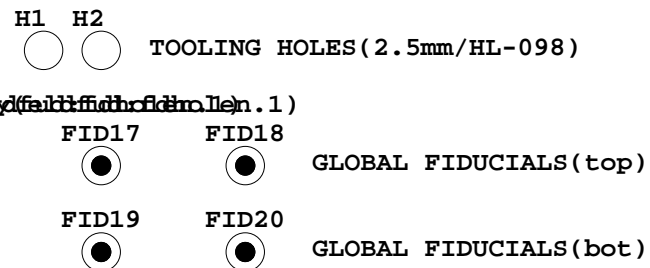

ADDITIONAL MECHANICAL DATA

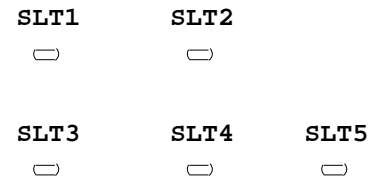
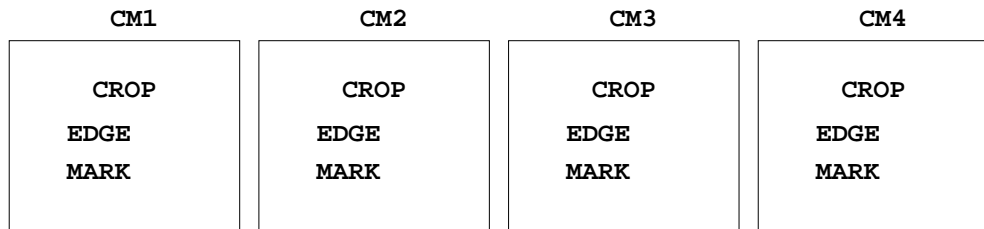
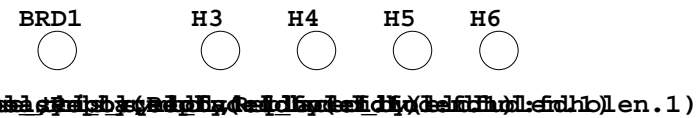

NOTE: ADDITIONAL MECHANICAL/ELECTRICAL REQUIREMENTS

TO BE ADDED TO THIS TABLE.

NO. MS-XXXX-3458-XX						
DATE	LET	REVISIONS	CG	MAN	CK	APP
		Modified key-in wetting current circuit P. L'Enfant, 20th October 2000				
		Changed 1A diodes to GF1G P. L'Enfant, 25th October 2000				
		D3, D14 Diode change Mark Lansley June 2001				

PART MUST COMPLY WITH SPECIFICATION WSS-M99P9999-A1
TO HELP SAFEGUARD HEALTH, SAFETY AND THE ENVIRONMENT

Visteon **PRODUCT ENGINEERING**

COMPUTER MANUAL "C" SIZE

CG COLUMN = GRAPHIC DATA LEVEL ORIGINAL WHEN RED

DO NOT SCALE ABOVE SCALE FOR REFERENCE ONLY

REF	PROJECT/SCH/SCH_NAME	DRAWN BY	DATE	CHECKED	SCALE	APPROVED
			YYMMDD		NONE	

UNLESS OTHERWISE SPECIFIED:
 DIMENSIONS ARE IN INCHES MILLIMETERS
 MACHINED DIM. +/-
 ANGULAR DIM. +/-

3RD ANGLE PROJECTION
STAMPED DIM. +/-

MATERIAL	APP
	DATE

NAME SKETCH - WIRING DIAGRAM
(DRAWING_NAME)

NO. **MS-XXXX-3458-XX**

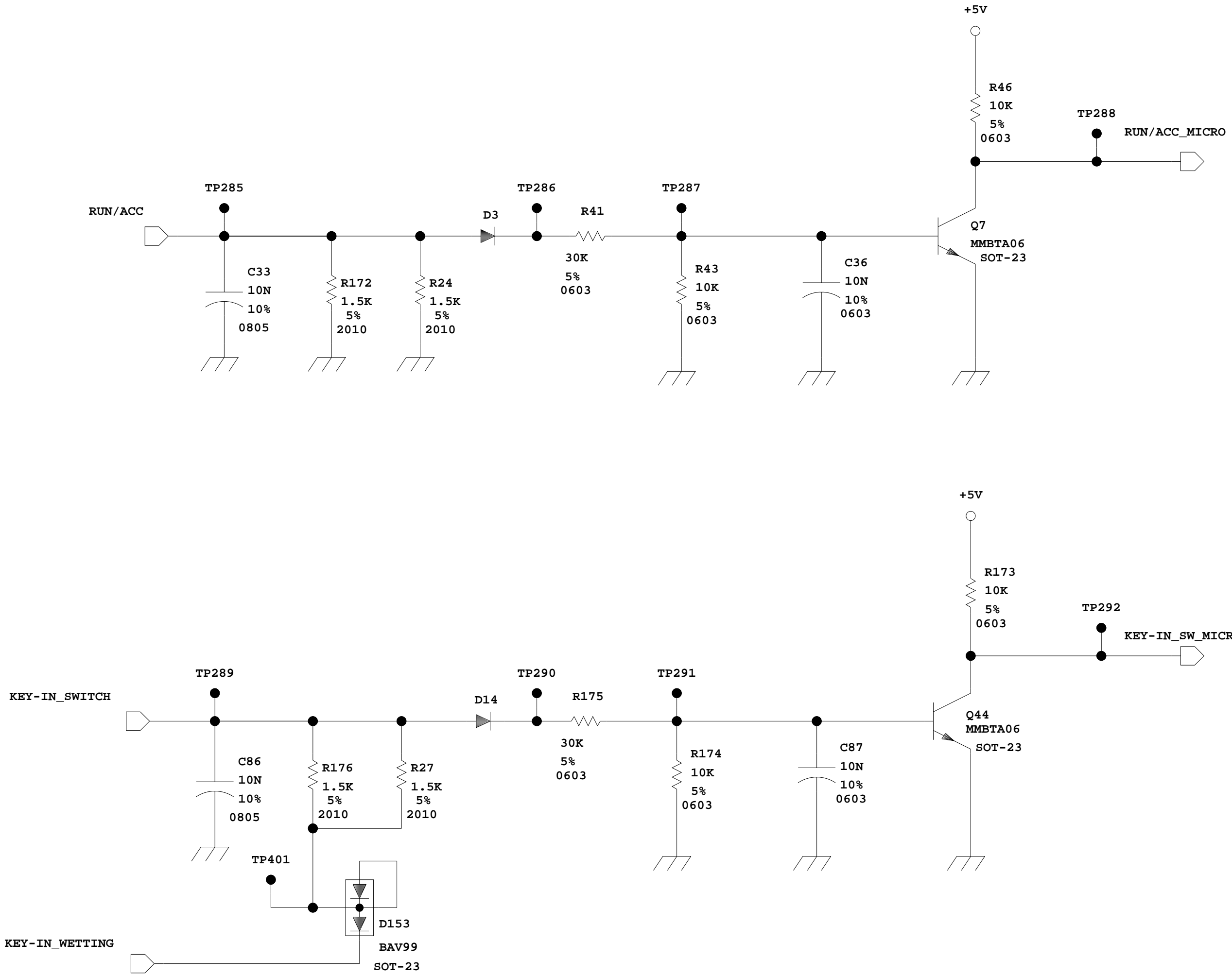

X355 "IGNITION SW INTERFACE" PWB12418 :- SHEET 4

NO. MS-XXXX-3458-XX						
DATE	LET	REVISIONS	CG	MAN	CK	APP
		Moved column position pot circuits from column FUB to interface FUB				
		Modified dimmer and position pot circuits in line with new X202 design for supply of feed to pots				
		P. L'Enfant, 11th December 2000				
		Added R226 to dimmer feed circuit to allow short circuit to battery detection				
		P. L'Enfant, 30th January 2001				
		D155, D156, D158, D159 Diode change				
		Mark Lansley June 2001				

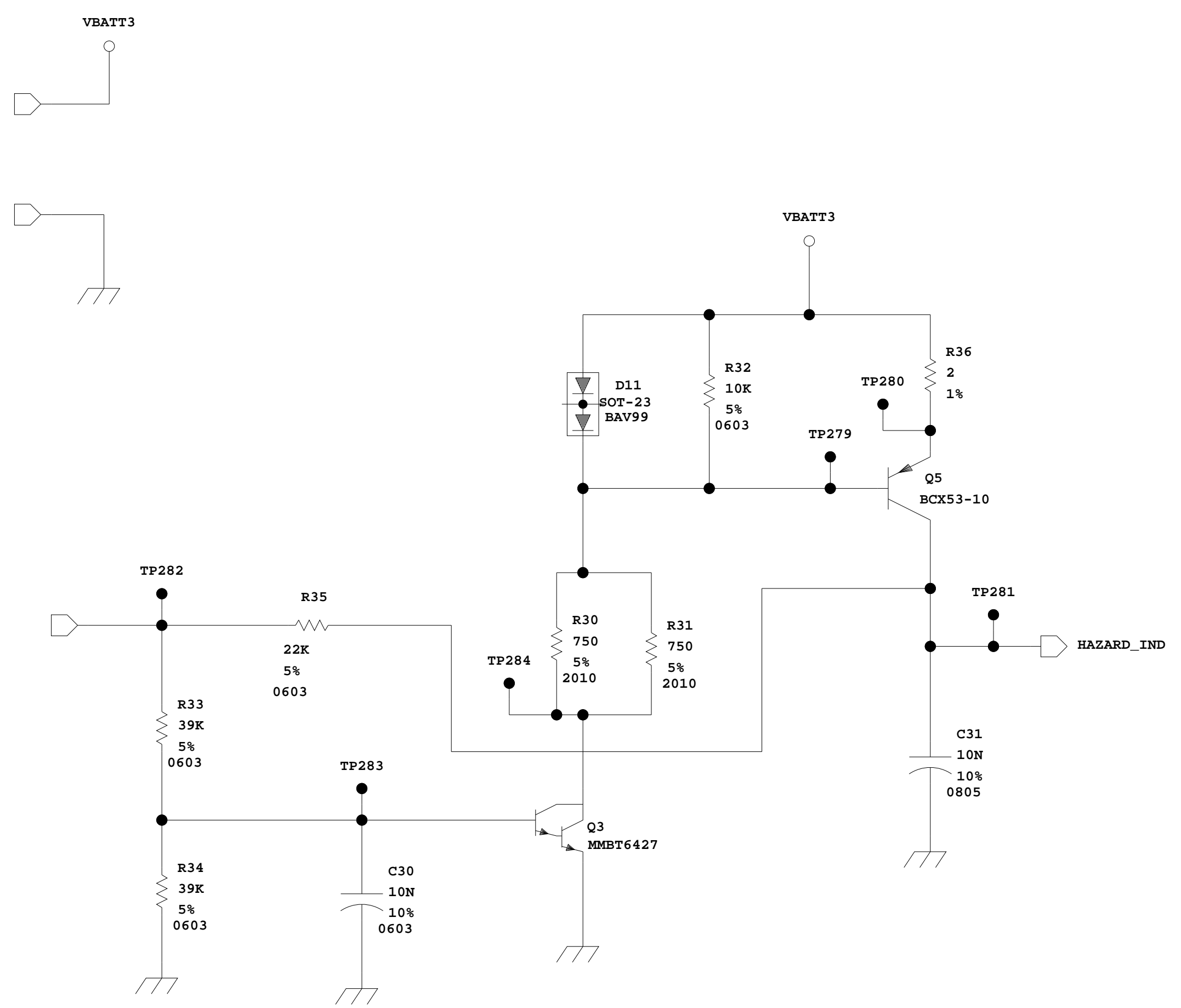
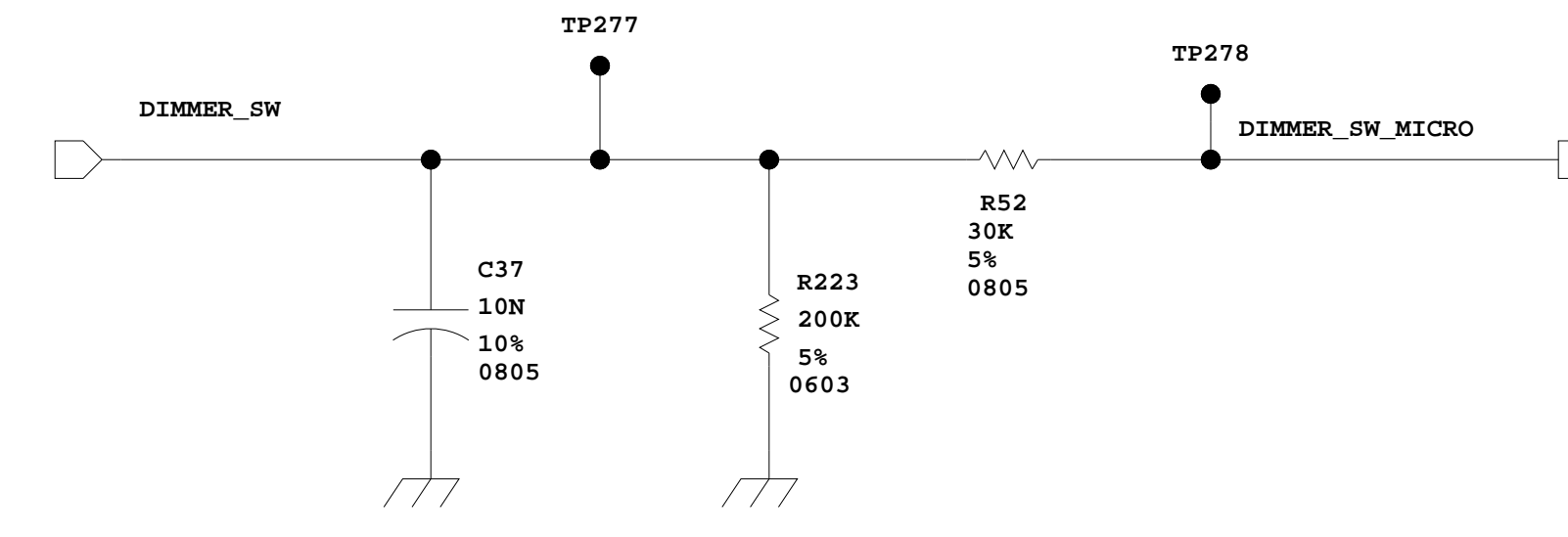
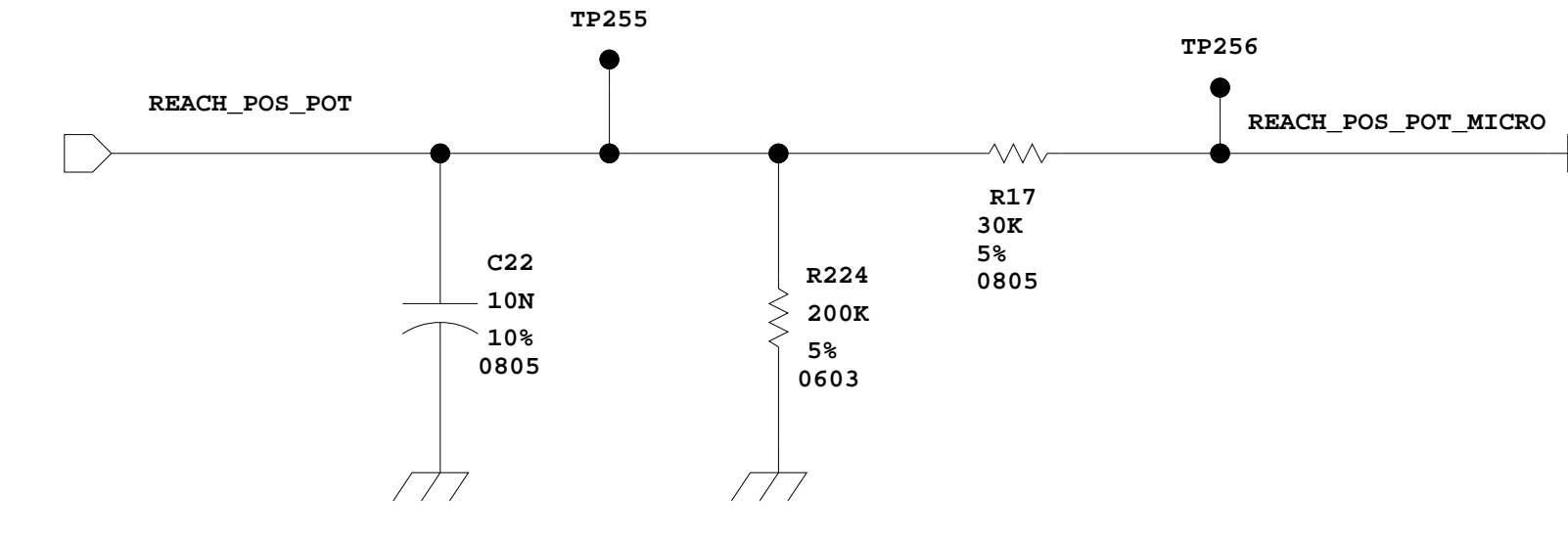
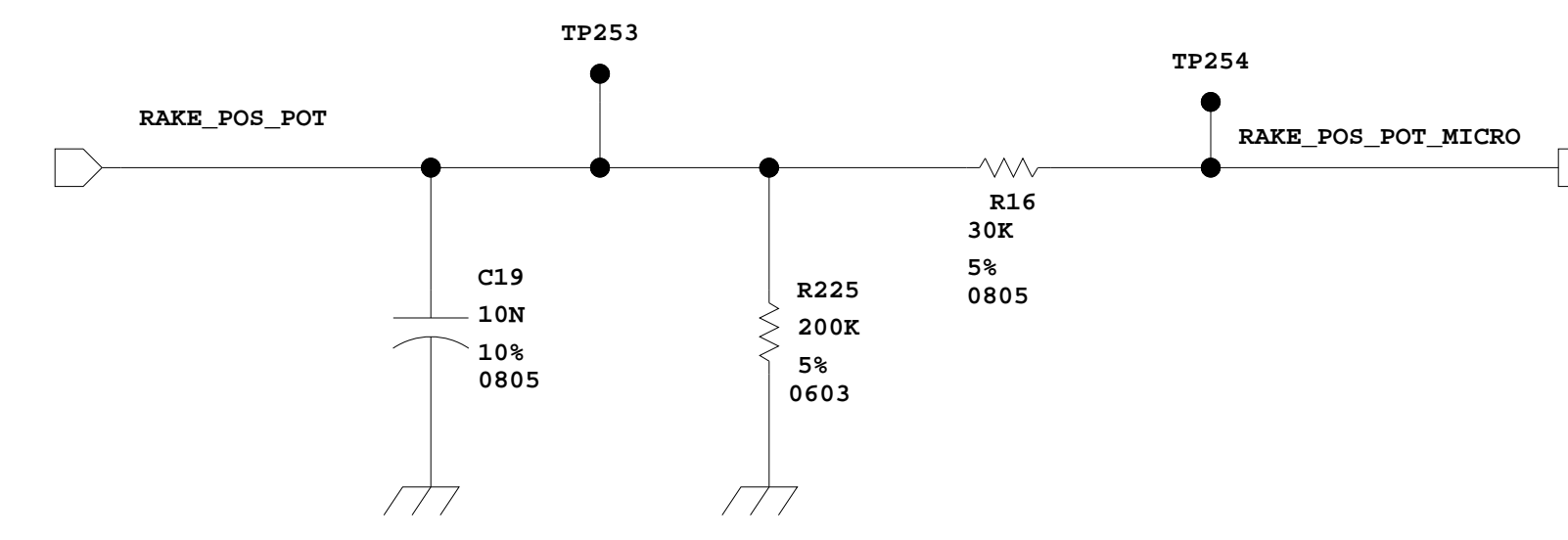
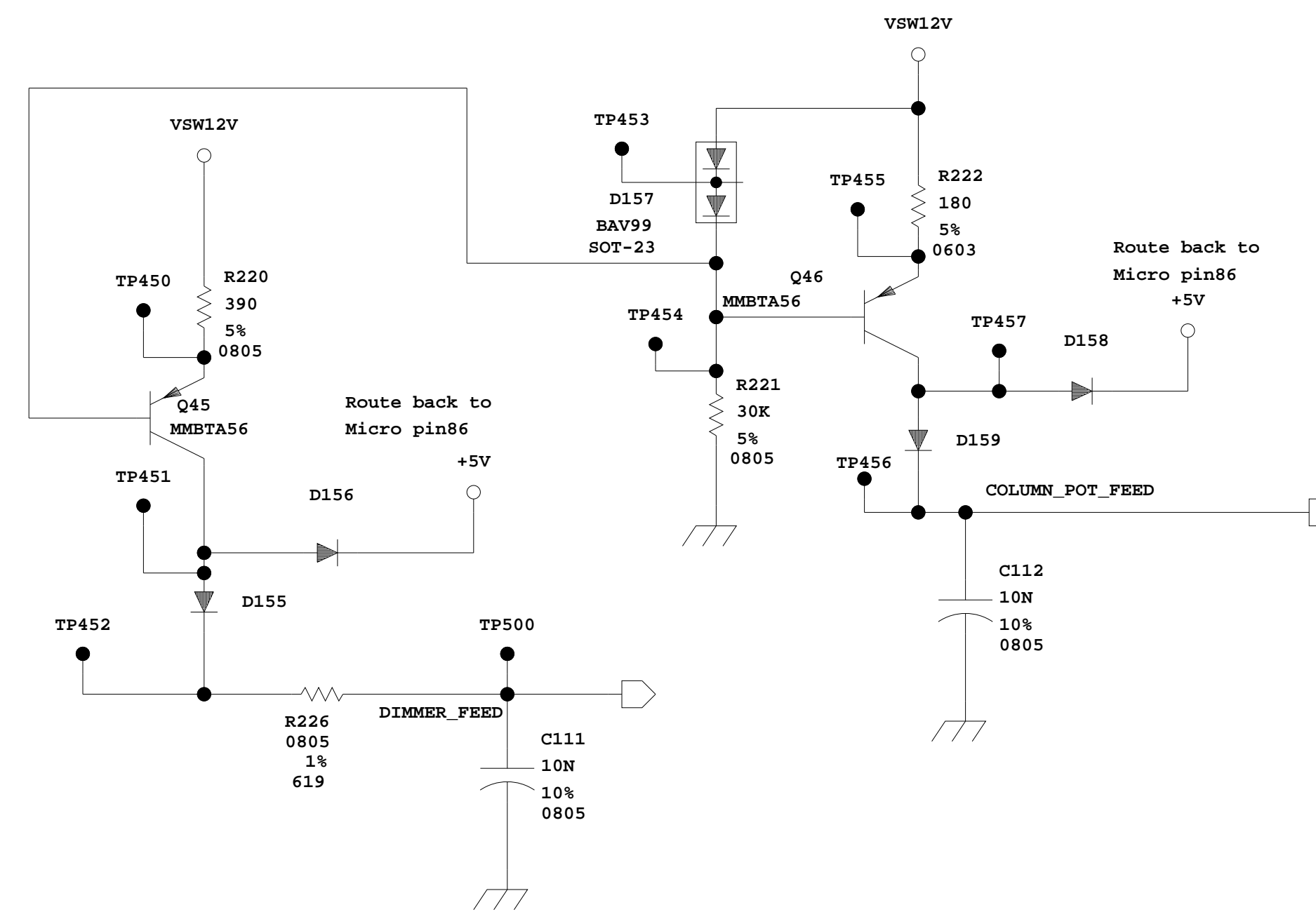
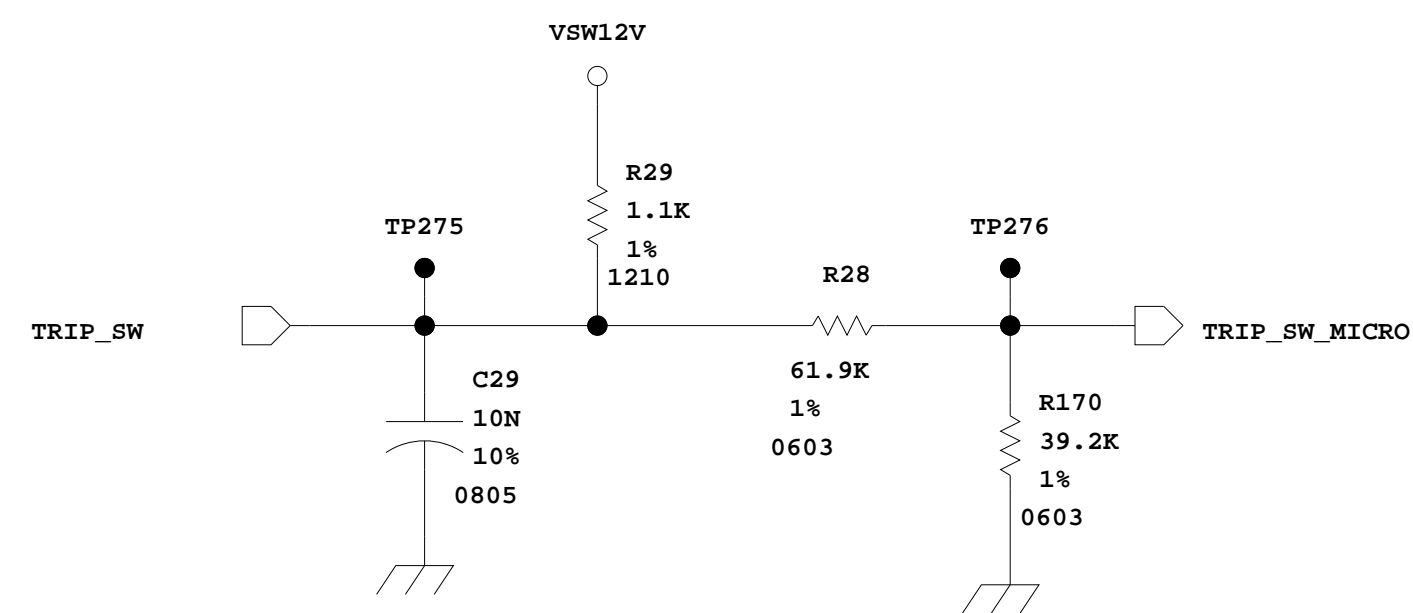
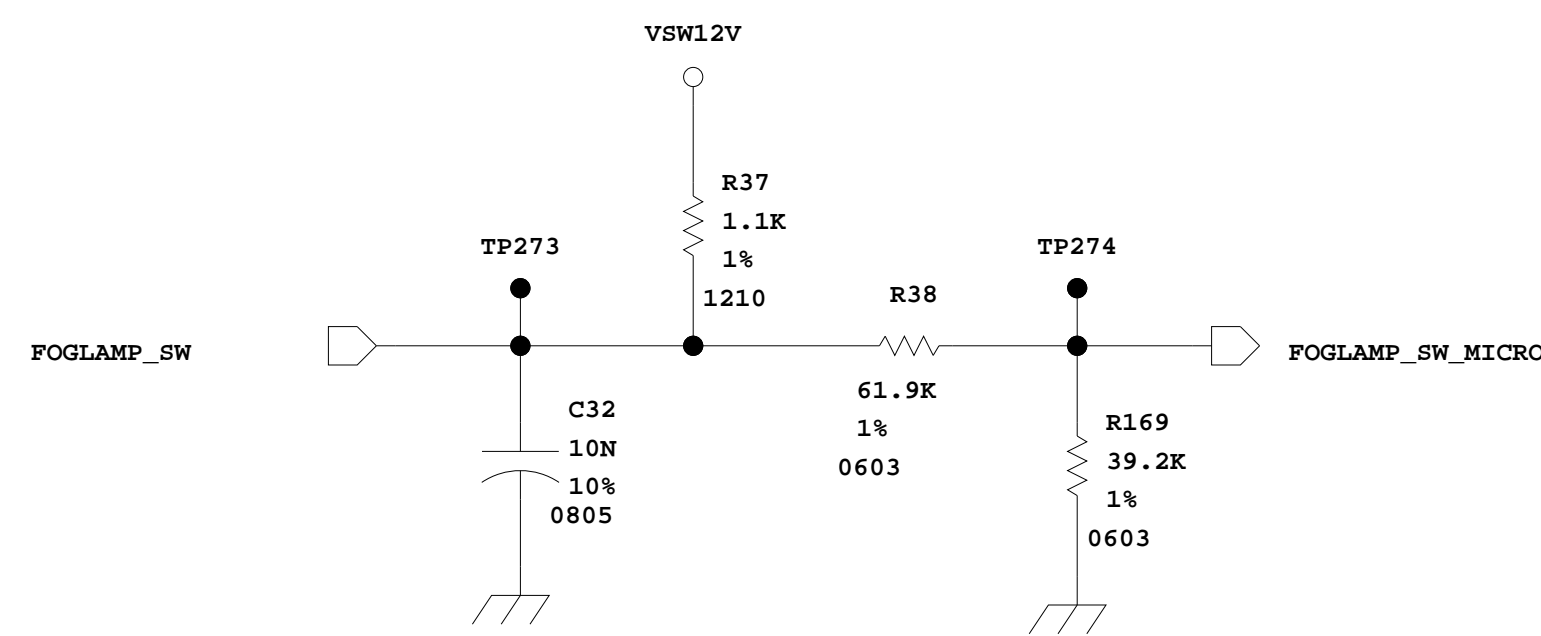

PART MUST COMPLY WITH SPECIFICATION WSS-M99F9999-A1 TO HELP SAFEGUARD HEALTH, SAFETY AND THE ENVIRONMENT

Visteon PRODUCT ENGINEERING

COMPUTER MANUAL "D" SIZE

CG COLUMN = GRAPHIC DATA LEVEL ORIGINAL WHEN RED

ENGLISH 1 2 3 4 5 6
METRIC 20 30 40 50 60 70 80 90 100 110 120 130 140 150 160

DO NOT SCALE ABOVE SCALE FOR REFERENCE ONLY

REF	PROJECT/SCH/SCH_NAME
DRAWN BY	DATE
CHECKED	SCALE
YYMMDD	NONE
APPROVED	

UNLESS OTHERWISE SPECIFIED:
DIMENSIONS ARE IN
 INCHES MILLIMETERS
MACHINED DIM. +/-
ANGULAR DIM. +/-

3RD ANGLE PROJECTION
STAMPED DIM. +/-

MATERIAL	APP
	DATE

NAME SKETCH - WIRING DIAGRAM (DRAWING_NAME)

NO. MS-XXXX-3458-XX

X355 "SWITCH GEAR INTERFACE" PWB12418 :- SHEET 5

NO. MS-XXXX-3458-XX

DATE	LET	REVISIONS	CG	MAN	CK	APP

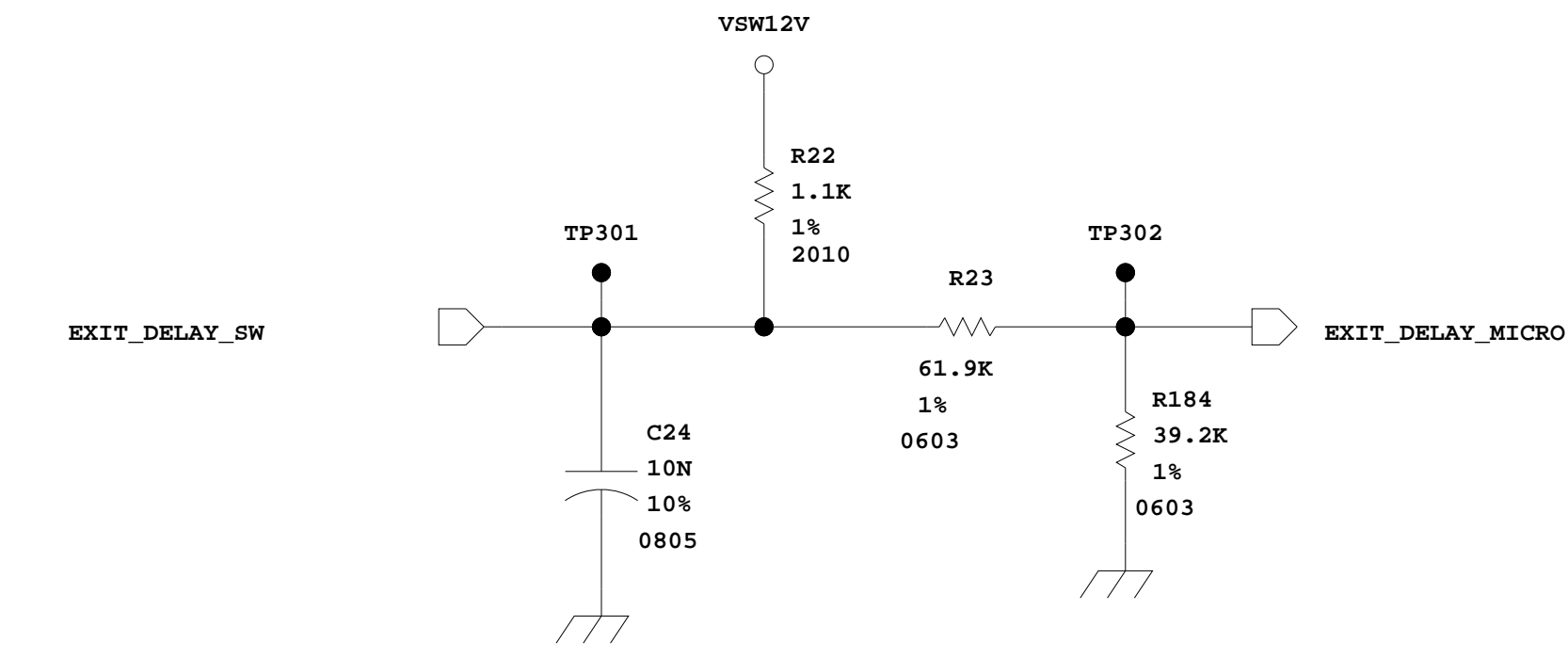
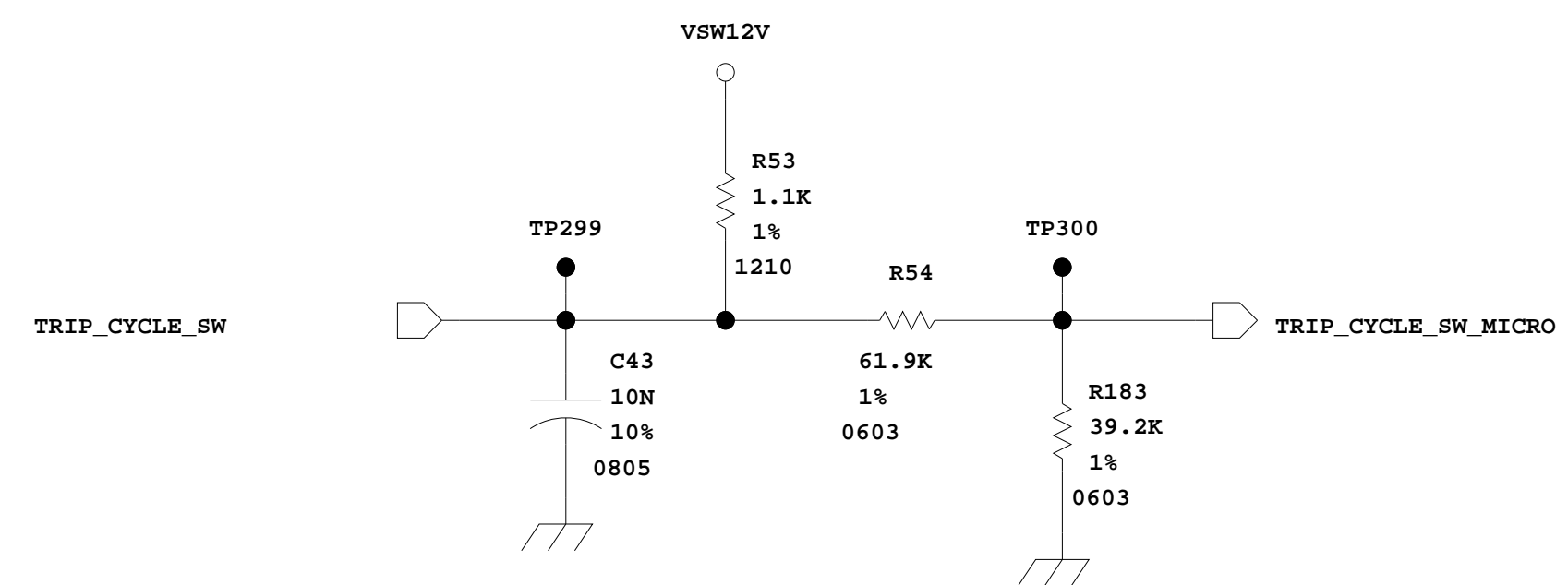
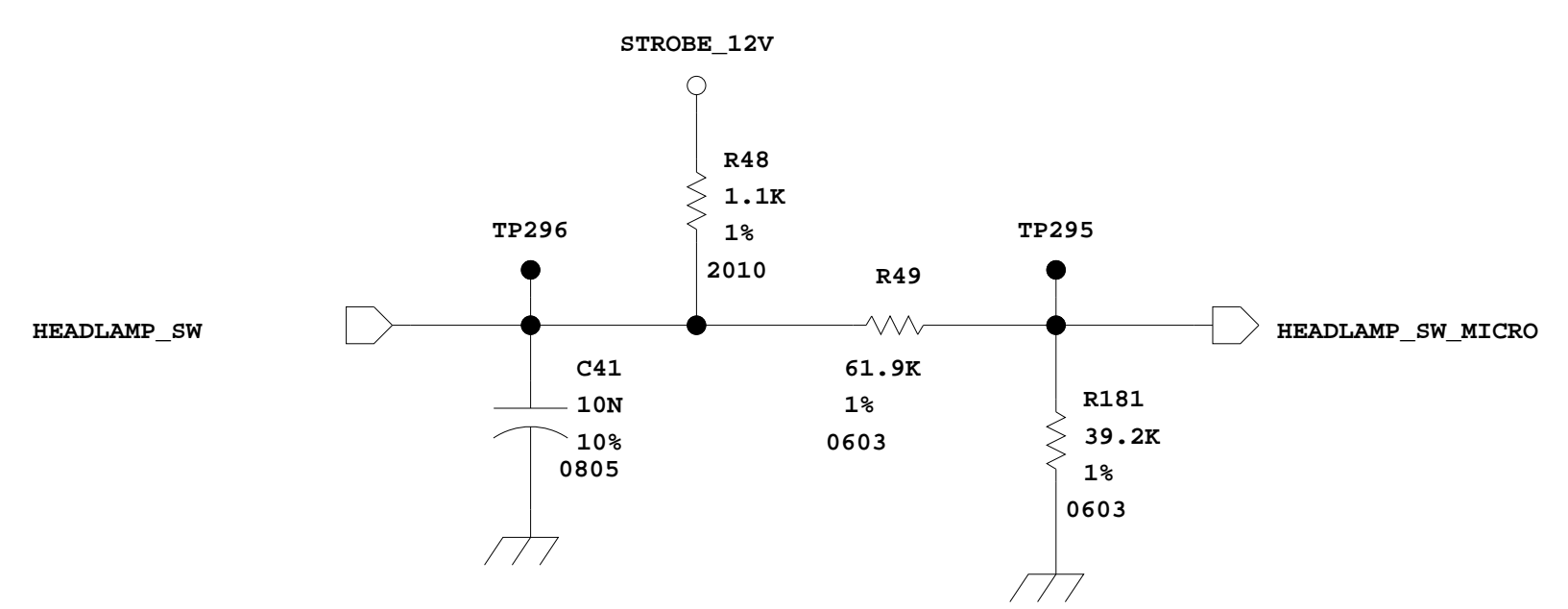
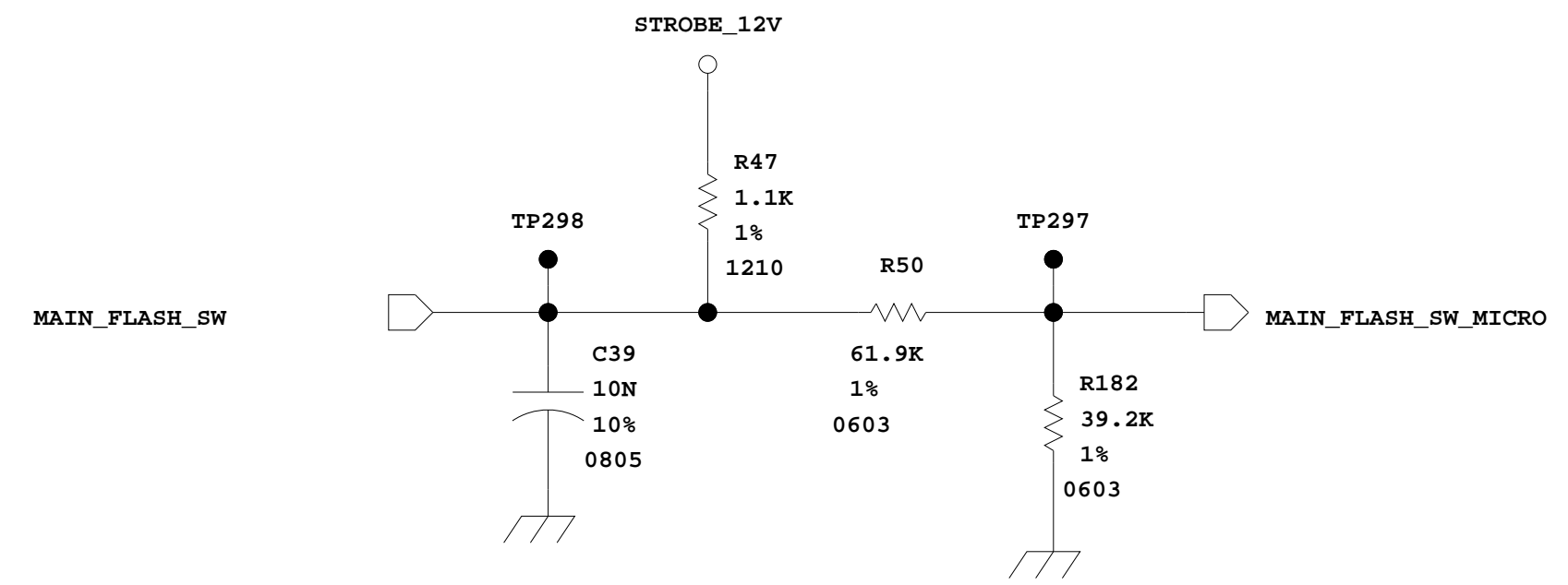
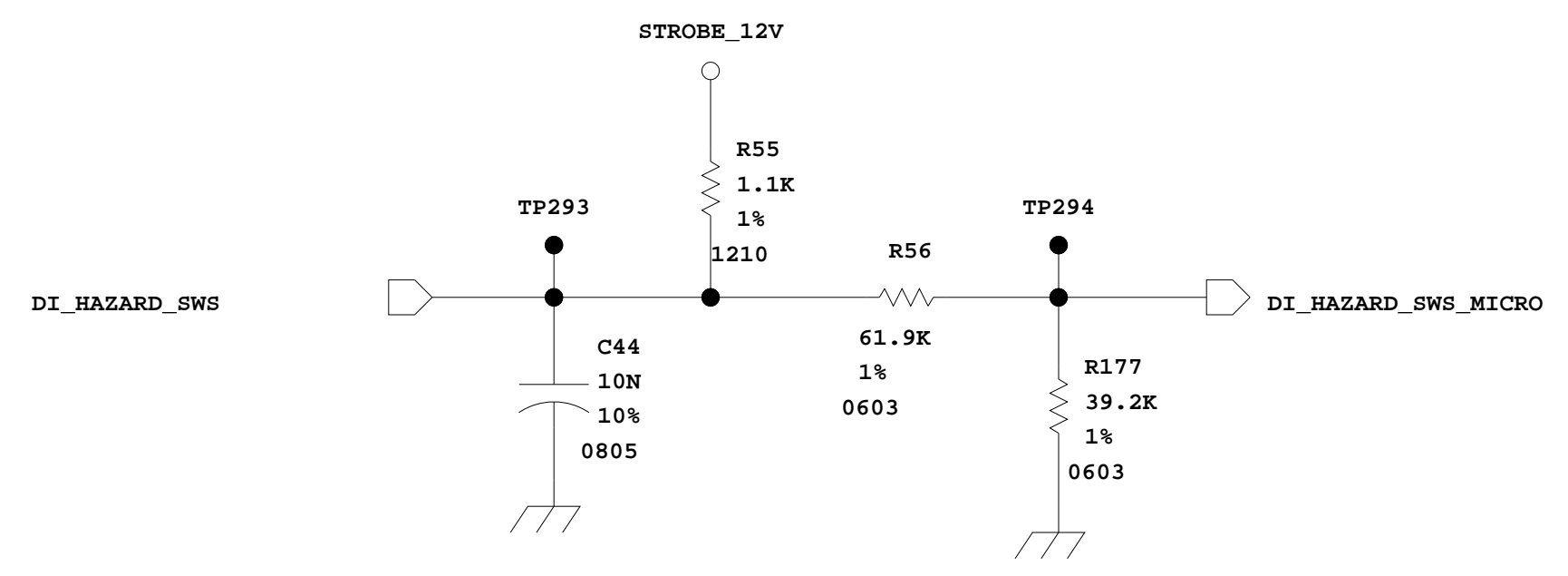
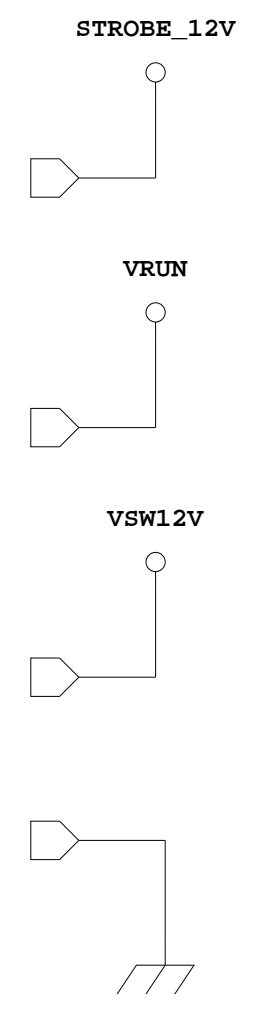

PART MUST COMPLY WITH SPECIFICATION WSS-M99F9999-A1 TO HELP SAFEGUARD HEALTH, SAFETY AND THE ENVIRONMENT

Visteon PRODUCT ENGINEERING

COMPUTER MANUAL "D" SIZE

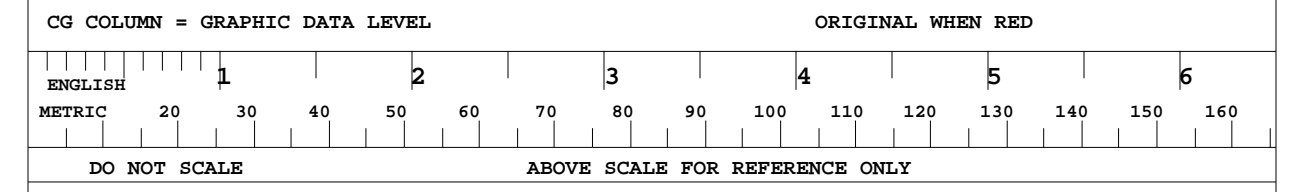

REF	PROJECT/SCH/SCH_NAME	DATE	CHECKED	SCALE	APPROVED
				NONE	

UNLESS OTHERWISE SPECIFIED:
 DIMENSIONS ARE IN INCHES MILLIMETERS
 MACHINED DIM. +/- 3RD ANGLE PROJECTION
 ANGULAR DIM. +/- STAMPED DIM. +/-

MATERIAL	APP
	DATE

NAME SKETCH - WIRING DIAGRAM (DRAWING_NAME)

NO. MS-XXXX-3458-XX

X355 "STALK INTERFACE" PWB12418 :- SHEET 6

NO.		MS-XXXX-3458-XX				
DATE	LET	REVISIONS	CG	MAN	CK	APP
		R89, R90 changed package size Mark Lansley May 2001				

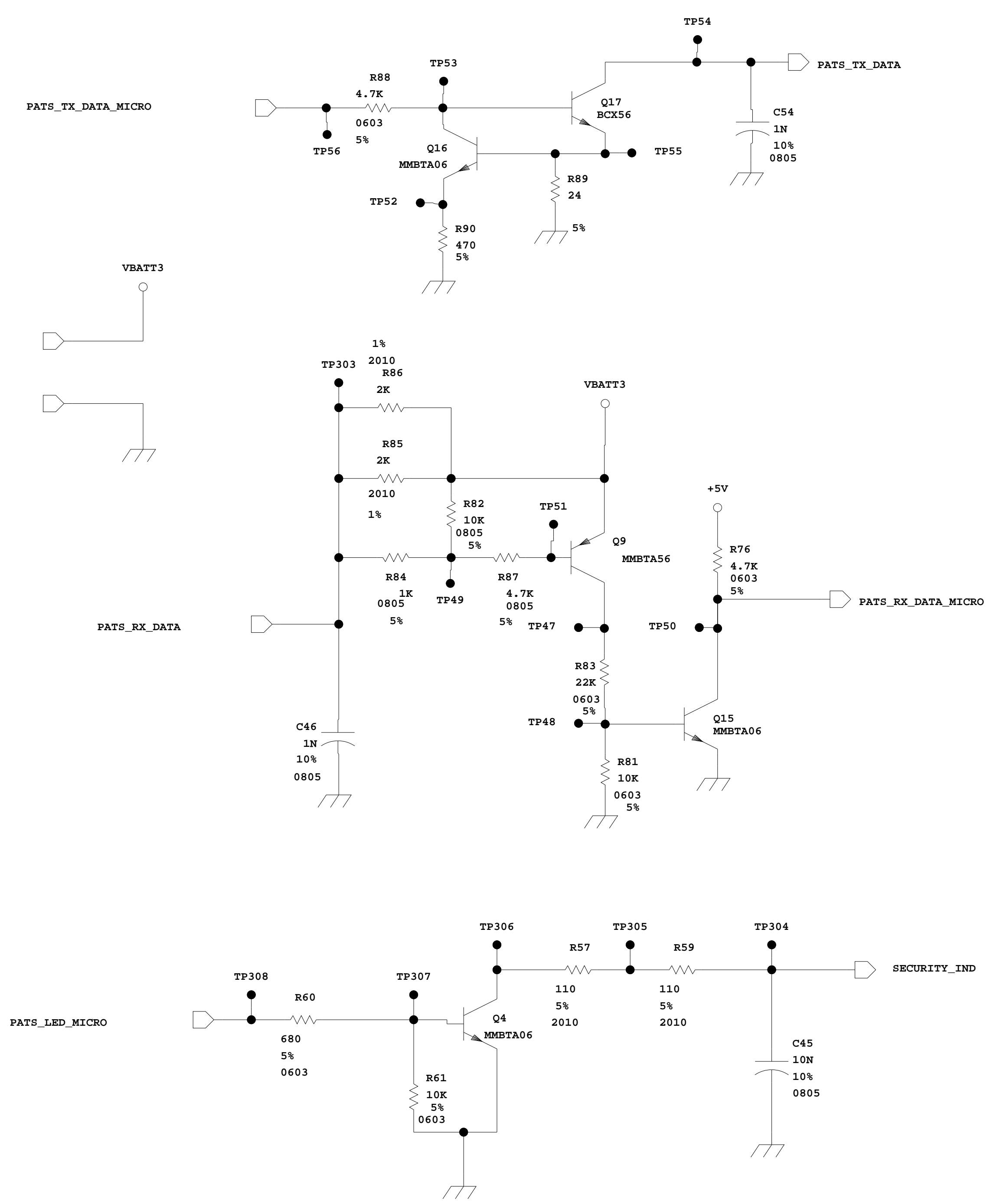

PART MUST COMPLY WITH SPECIFICATION WSS-M99P9999-A1 TO HELP SAFEGUARD HEALTH, SAFETY AND THE ENVIRONMENT

Visteon PRODUCT ENGINEERING

COMPUTER MANUAL "C" SIZE

CG COLUMN = GRAPHIC DATA LEVEL ORIGINAL WHEN RED

ENGLISH METRIC 20 30 40 50 60 70 80 90 100 110 120 130 140 150 160

DO NOT SCALE ABOVE SCALE FOR REFERENCE ONLY

REF	PROJECT/SCH/SCH_NAME			
DRAWN BY	DATE	CHECKED	SCALE	APPROVED
	YYMMDD		NONE	

UNLESS OTHERWISE SPECIFIED:
 DIMENSIONS ARE IN INCHES MILLIMETERS
 MACHINED DIM. +/-
 ANGULAR DIM. +/-

3RD ANGLE PROJECTION
 STAMPED DIM. +/-

MATERIAL	APP
	DATE

NAME SKETCH - WIRING DIAGRAM (DRAWING_NAME)

NO. **MS-XXXX-3458-XX**

X355 "PATS INTERFACE" PWB12418 :- SHEET 7

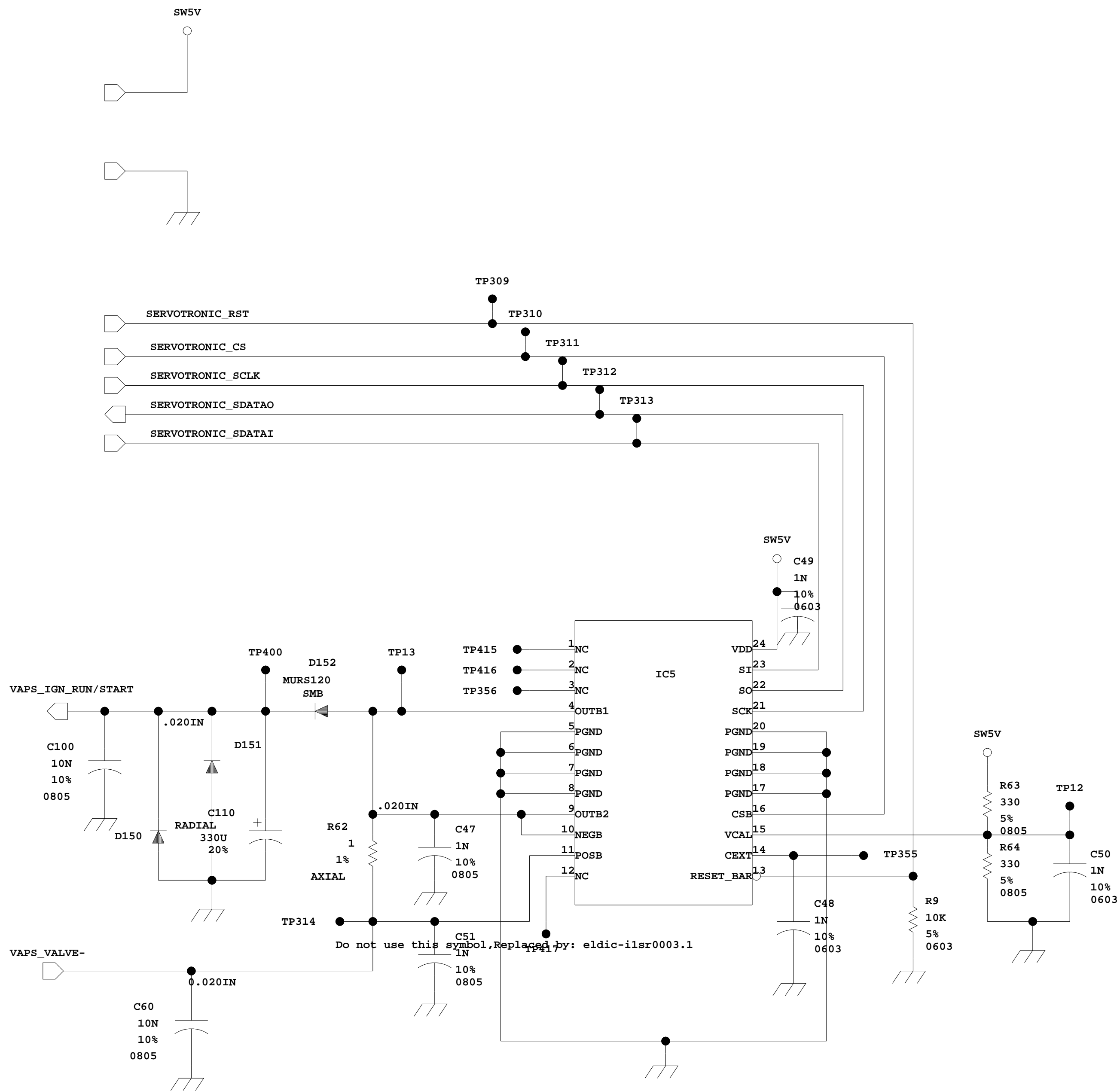

NO. **MS-XXXX-3458-XX**

DATE	LET	REVISIONS	CG	MAN	CK	APP
		Changed power side of VAPS circuit for EMC P. L'Enfant, 20th October 2000				
		D150, D151 Diode change Mark Lansley June 2001				

PART MUST COMPLY WITH SPECIFICATION WSS-M99P9999-A1 TO HELP SAFEGUARD HEALTH, SAFETY AND THE ENVIRONMENT

Visteon PRODUCT ENGINEERING

COMPUTER MANUAL "C" SIZE

CG COLUMN = GRAPHIC DATA LEVEL ORIGINAL WHEN RED

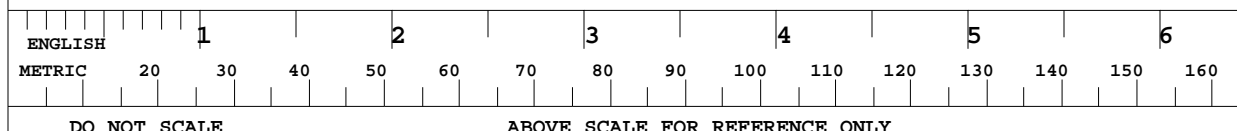

REF	PROJECT/SCH/SCH_NAME	DRAWN BY	DATE	CHECKED	SCALE	APPROVED
			YYMMDD		NONE	

UNLESS OTHERWISE SPECIFIED:
 DIMENSIONS ARE IN INCHES MILLIMETERS
 MACHINED DIM. +/-
 ANGULAR DIM. +/-

3RD ANGLE PROJECTION
 STAMPED DIM. +/-

MATERIAL	APP
	DATE

NAME SKETCH - WIRING DIAGRAM (DRAWING_NAME)

NO. **MS-XXXX-3458-XX**

ADD 150 MILLIMETRES SQUARED AROUND THE 8 CENTRAL GROUND PIN HEAT SPREADERS OF IC5

X355 "ZF STEERING" PWB12418 :- SHEET 8

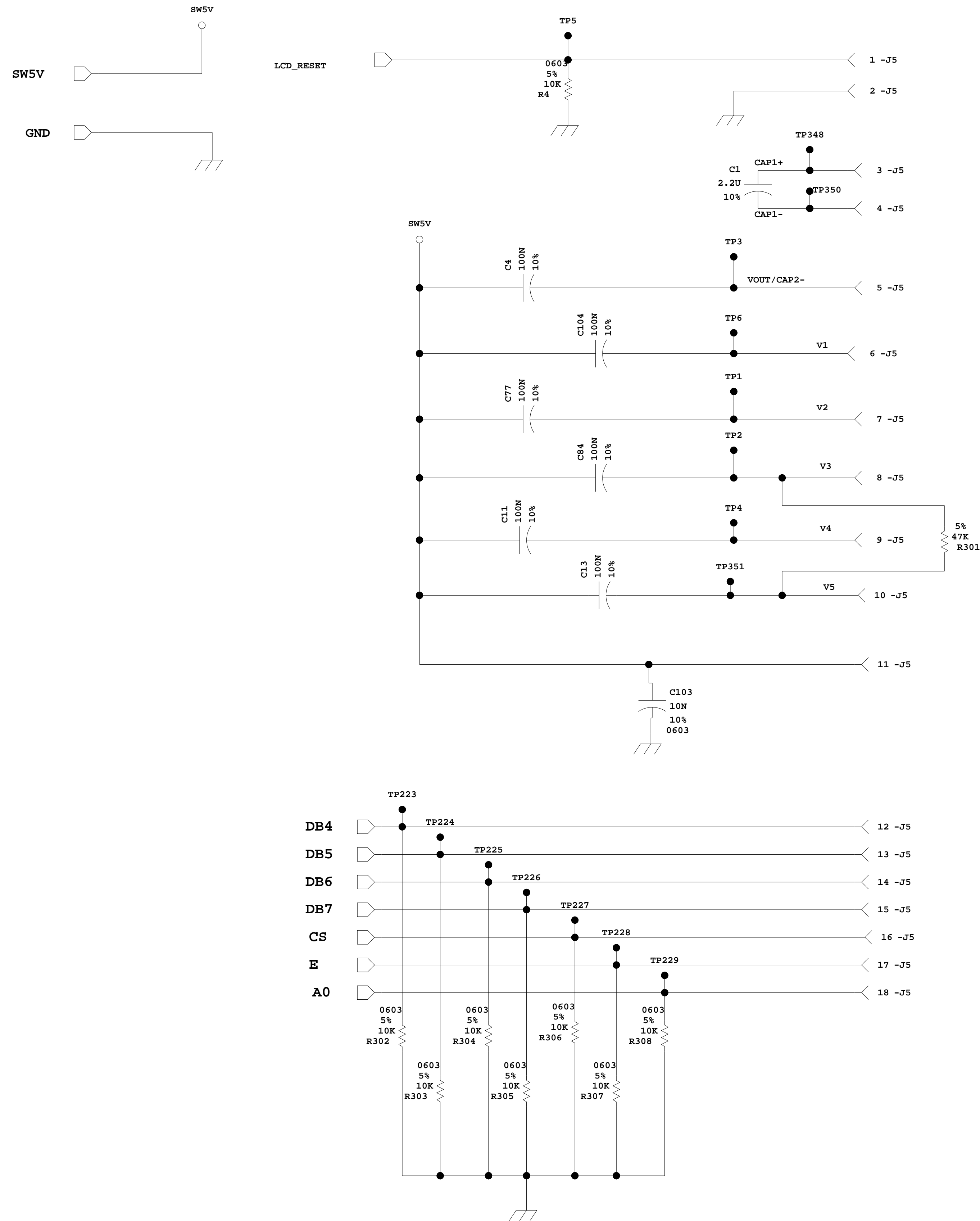

NO. MS-XXXX-3458-XX

DATE	LET	REVISIONS	CG	MAN	CK	APP
		Changed capacitors and added resistor for message centre to reduce Flare up when powered on M. Lansley, 11 April 2001				

PART MUST COMPLY WITH SPECIFICATION WSS-M99F9999-A1 TO HELP SAFEGUARD HEALTH, SAFETY AND THE ENVIRONMENT

Visteon PRODUCT ENGINEERING

COMPUTER MANUAL "D" SIZE

CG COLUMN = GRAPHIC DATA LEVEL ORIGINAL WHEN RED

ENGLISH 1 2 3 4 5 6
METRIC 20 30 40 50 60 70 80 90 100 110 120 130 140 150 160

DO NOT SCALE ABOVE SCALE FOR REFERENCE ONLY

REF	PROJECT/SCH/SCH_NAME

DRAWN BY	DATE	CHECKED	SCALE	APPROVED
	YYMMDD		NONE	

UNLESS OTHERWISE SPECIFIED:
 DIMENSIONS ARE IN INCHES MILLIMETERS
 MACHINED DIM. +/- 3RD ANGLE PROJECTION
 ANGULAR DIM. +/- STAMPED DIM. +/-

MATERIAL	APP
	DATE

NAME SKETCH - WIRING DIAGRAM (DRAWING_NAME)

NO. MS-XXXX-3458-XX

X355 "MESSAGE CENTRE" PWB12418 :- SHEET 19

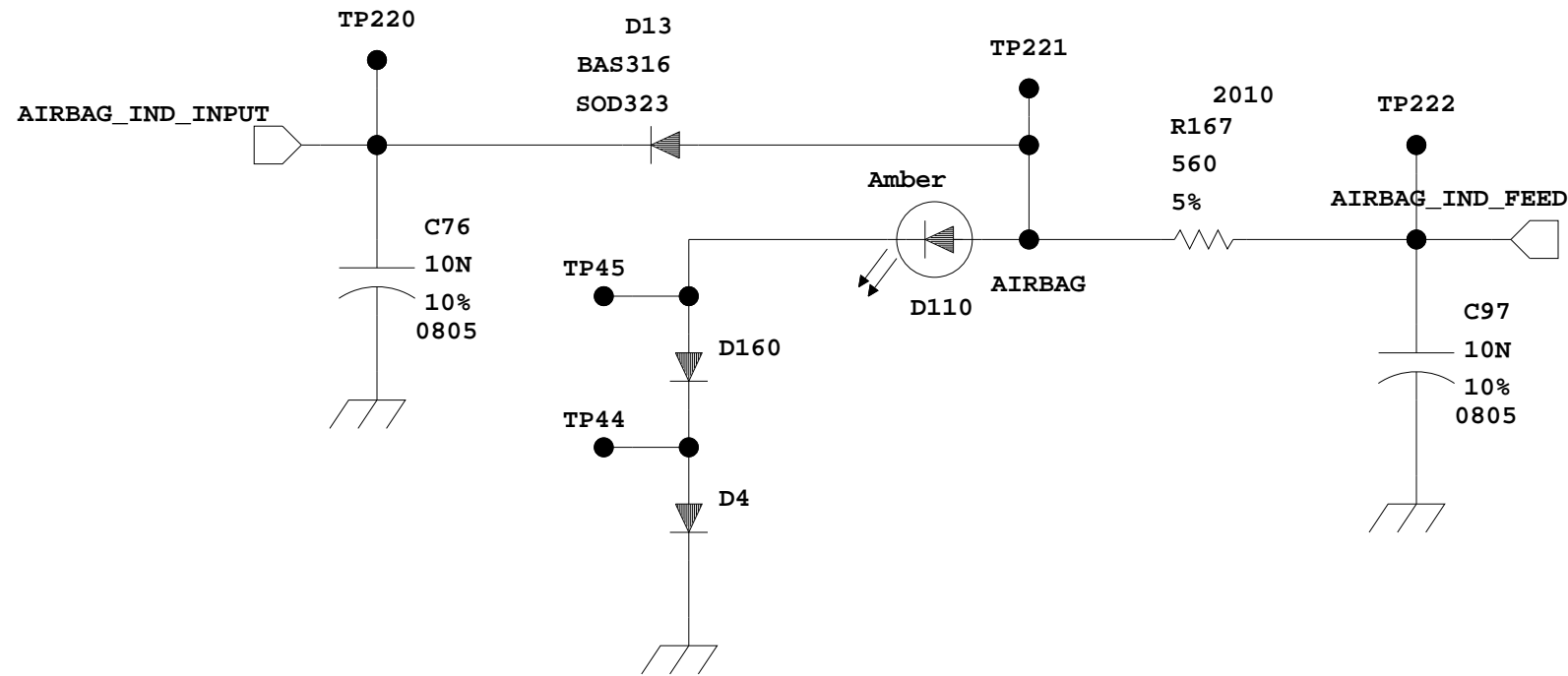

NO. **MS-XXXX-3458-XX**

DATE	LET	REVISIONS	CG	MAN	CK	APP
		Changed 1A diodes to GF1G P. L'Enfant, 25th October 2000				
		Changed zener diode to GF1G P. L'Enfant, 11th December 2000				
		D4, D160 Diode change Mark Lansley June 2001				

PART MUST COMPLY WITH SPECIFICATION WSS-M99P9999-A1 TO HELP SAFEGUARD HEALTH, SAFETY AND THE ENVIRONMENT

Visteon **PRODUCT ENGINEERING**

COMPUTER MANUAL **"B"** SIZE

CG COLUMN = GRAPHIC DATA LEVEL ORIGINAL WHEN RED

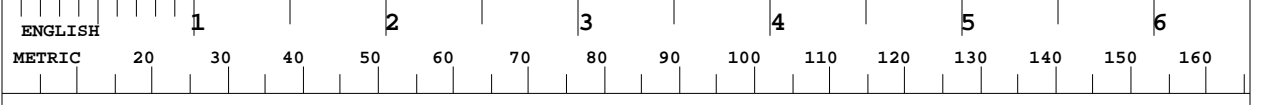

REF PROJECT/SCH/SCH_NAME

DRAWN BY	DATE	CHECKED	SCALE	APPROVED
	YYMMDD		NONE	

UNLESS OTHERWISE SPECIFIED:
 DIMENSIONS ARE IN INCHES MILLIMETERS
 MACHINED DIM. +/-
 ANGULAR DIM. +/-

3RD ANGLE PROJECTION
 STAMPED DIM. +/-

MATERIAL	APP
	DATE

NAME **SKETCH - WIRING DIAGRAM**
(DRAWING_NAME)

NO. **MS-XXXX-3458-XX**

PWB

PLANT CODE:

X355 "EXT WARNINGS" PWB12418 :- SHEET 18 POWERVIEW

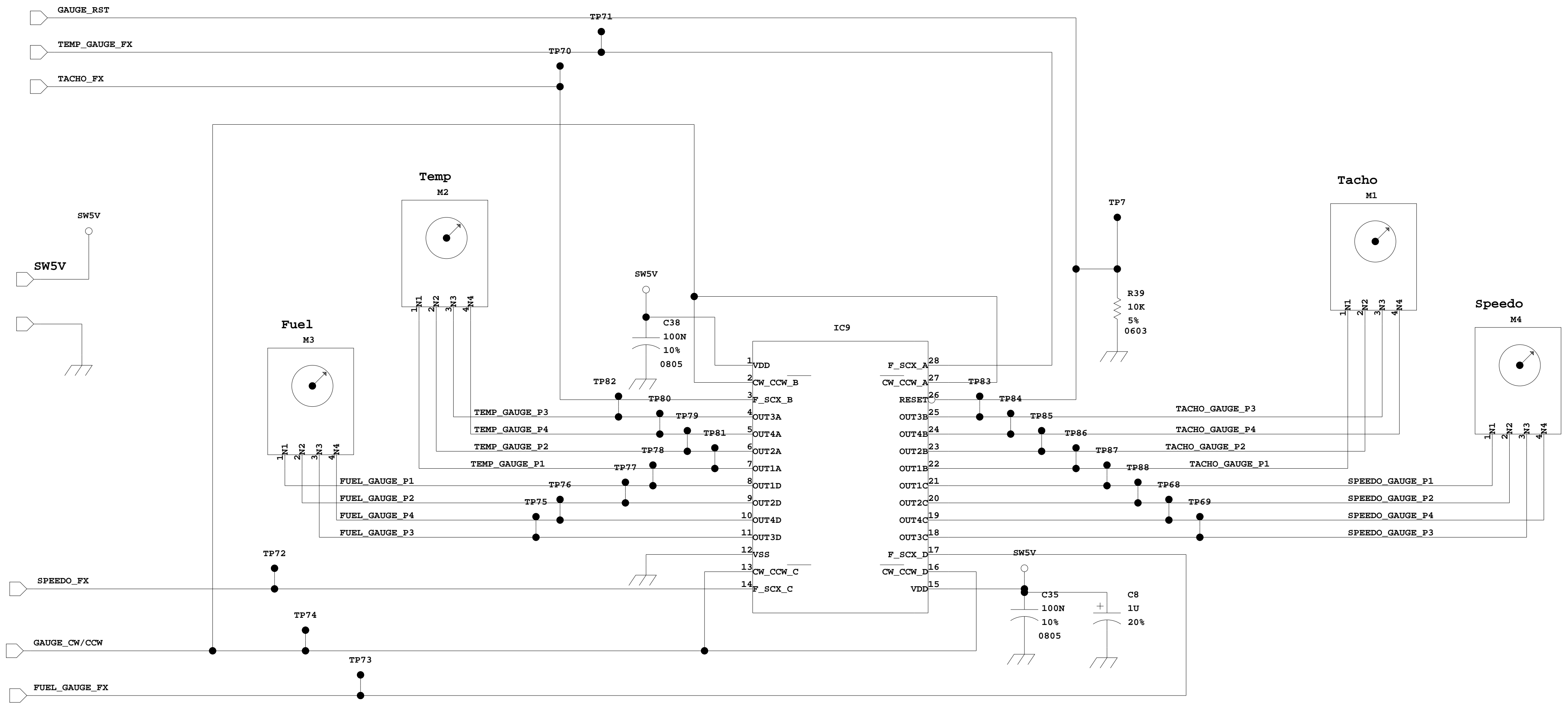

TEST POINTS TP75, TP76, TP77, TP78, TP79, TP80, TP81, TP82, TP83, TP84, TP85, TP86, TP87, TP88, TP68 AND TP69 ARE 0.100 INCH TO BE PLACED ON THE TOP SIDE OF THE BOARD AWAY FROM NON-SMD COMPONENTS

NO. MS-XXXX-3458-XX						
DATE	LET	REVISIONS	CG	MAN	CK	APP

PART MUST COMPLY WITH SPECIFICATION WSS-M99F9999-A1 TO HELP SAFEGUARD HEALTH, SAFETY AND THE ENVIRONMENT

Visteon PRODUCT ENGINEERING

COMPUTER MANUAL "D" SIZE

CG COLUMN = GRAPHIC DATA LEVEL ORIGINAL WHEN RED

ENGLISH 1 2 3 4 5 6
 METRIC 20 30 40 50 60 70 80 90 100 110 120 130 140 150 160

DO NOT SCALE ABOVE SCALE FOR REFERENCE ONLY

REF	PROJECT/SCH/SCH_NAME

DRAWN BY	DATE	CHECKED	SCALE	APPROVED
			NONE	

UNLESS OTHERWISE SPECIFIED:
 DIMENSIONS ARE IN INCHES MILLIMETERS
 MACHINED DIM. +/- 3RD ANGLE PROJECTION
 ANGULAR DIM. +/- STAMPED DIM. +/-

MATERIAL	APP
	DATE

NAME SKETCH - WIRING DIAGRAM (DRAWING_NAME)

NO. MS-XXXX-3458-XX

X355 "STEPPERS" PWB12418 :- SHEET 17

NO. MS-XXXX-3458-XX

DATE	LET	REVISIONS	CG	MAN	CK	APP

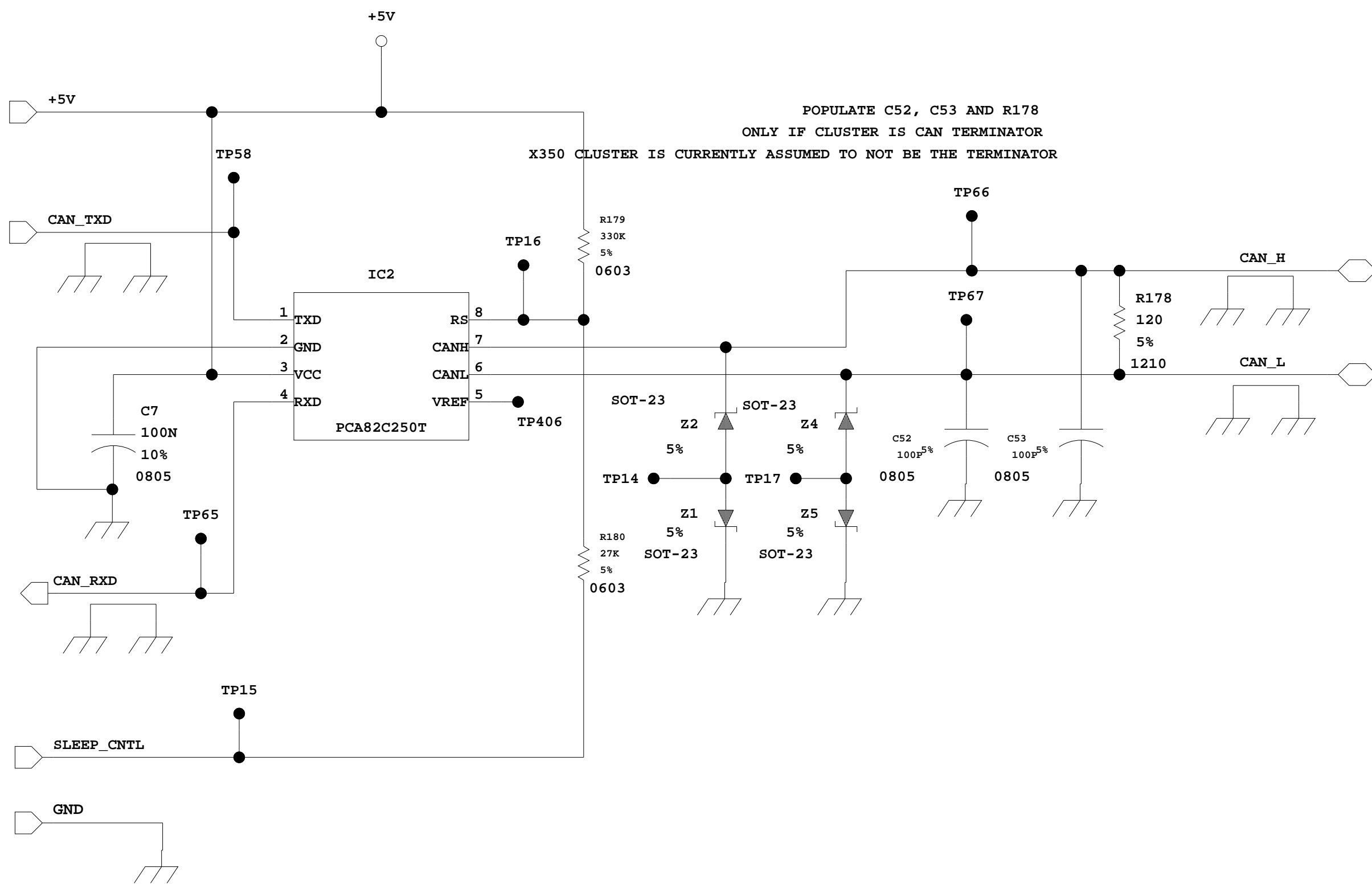

PART MUST COMPLY WITH SPECIFICATION WSS-M99P9999-A1 TO HELP SAFEGUARD HEALTH, SAFETY AND THE ENVIRONMENT

Visteon PRODUCT ENGINEERING

COMPUTER MANUAL "C" SIZE

CG COLUMN = GRAPHIC DATA LEVEL ORIGINAL WHEN RED

ENGLISH	1	2	3	4	5	6
METRIC	20	30	40	50	60	70
	80	90	100	110	120	130
	140	150	160			

DO NOT SCALE ABOVE SCALE FOR REFERENCE ONLY

REF	PROJECT/SCH/SCH_NAME

DRAWN BY	DATE	CHECKED	SCALE	APPROVED
	YYMMDD		NONE	

UNLESS OTHERWISE SPECIFIED:
 DIMENSIONS ARE IN INCHES MILLIMETERS
 MACHINED DIM. +/-
 ANGULAR DIM. +/-

3RD ANGLE PROJECTION
STAMPED DIM. +/-

MATERIAL	APP
	DATE

NAME SKETCH - WIRING DIAGRAM (DRAWING_NAME)

NO. MS-XXXX-3458-XX

X355 "CAN" PWB12418 :- SHEET 14

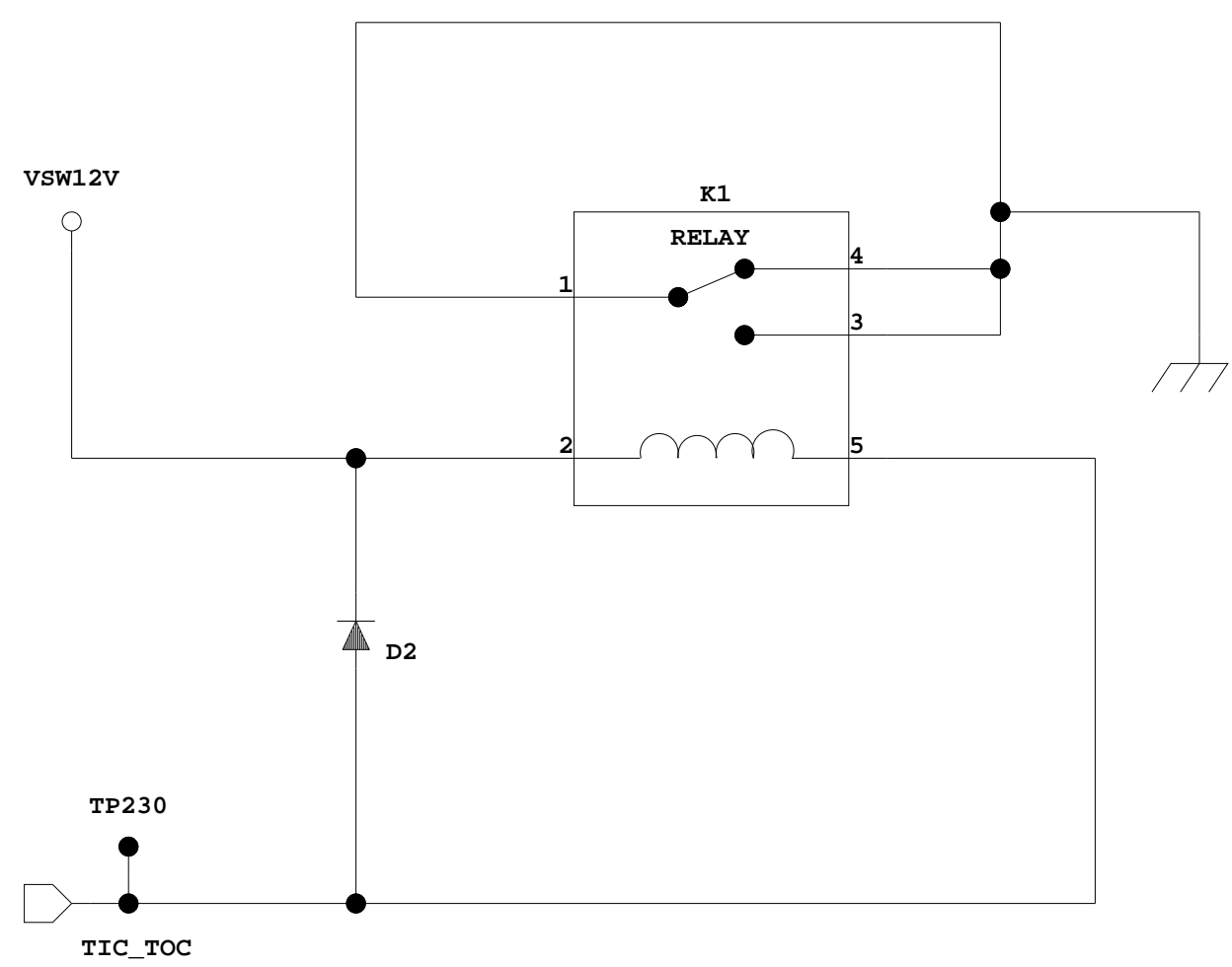
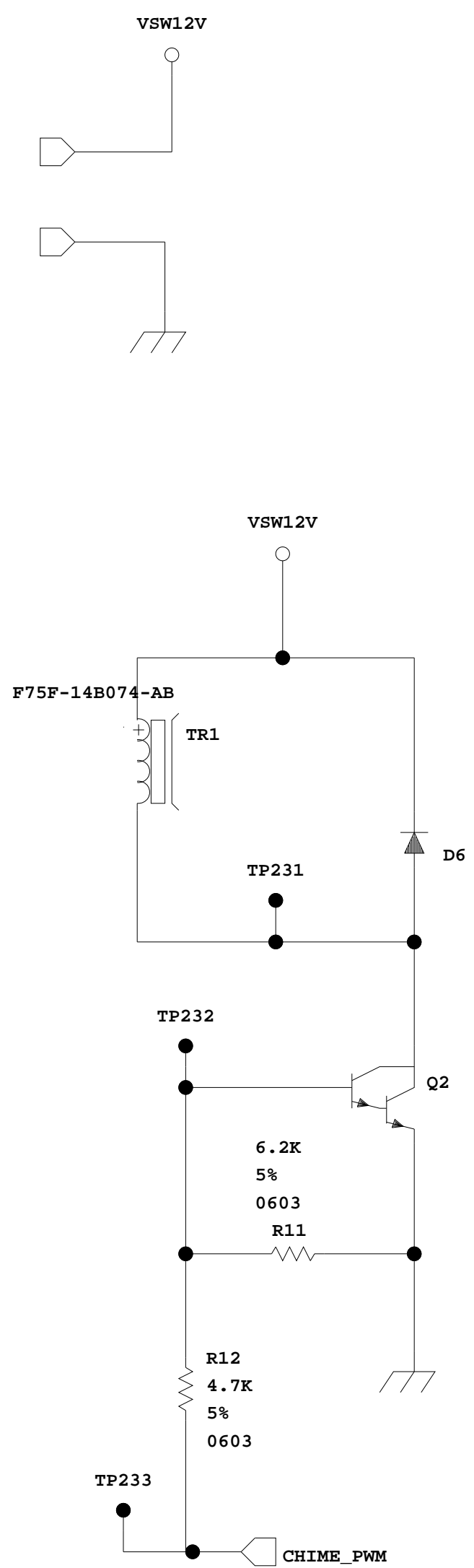

NO. **MS-XXXX-3458-XX**

DATE	LET	REVISIONS	CG	MAN	CK	APP
		Changed 1A diodes to GF1G P. L'Enfant, 25th October 2000				
		D2 D6 Diode change Mark Lansley June 2001				

PART MUST COMPLY WITH SPECIFICATION WSS-M99P9999-A1
TO HELP SAFEGUARD HEALTH, SAFETY AND THE ENVIRONMENT

Visteon PRODUCT ENGINEERING

COMPUTER MANUAL "C" SIZE

CG COLUMN = GRAPHIC DATA LEVEL ORIGINAL WHEN RED

ENGLISH 1 2 3 4 5 6
METRIC 20 30 40 50 60 70 80 90 100 110 120 130 140 150 160

DO NOT SCALE ABOVE SCALE FOR REFERENCE ONLY

REF	PROJECT/SCH/SCH_NAME	DRAWN BY	DATE	CHECKED	SCALE	APPROVED
			YYMMDD		NONE	

UNLESS OTHERWISE SPECIFIED:
DIMENSIONS ARE IN
 INCHES MILLIMETERS
MACHINED DIM. +/-
ANGULAR DIM. +/-

3RD ANGLE PROJECTION
STAMPED DIM. +/-

MATERIAL _____ APP _____
DATE _____

NAME SKETCH - WIRING DIAGRAM
(DRAWING_NAME)

NO. **MS-XXXX-3458-XX**

X355 "CHIME" PWB12418 :- SHEET 13

DATE	REV	REVISIONS	CO	MAN	CK	APP
		R136 changed to 3W part P. L'Herfant 19th December 2000				
		Added filtering C201/C202 Mark Lansley, March 2002				

LEDS D54 TO D59 ARE WHITE LWT673
ALL OTHER LEDES ON THIS SHEET ARE LPT670

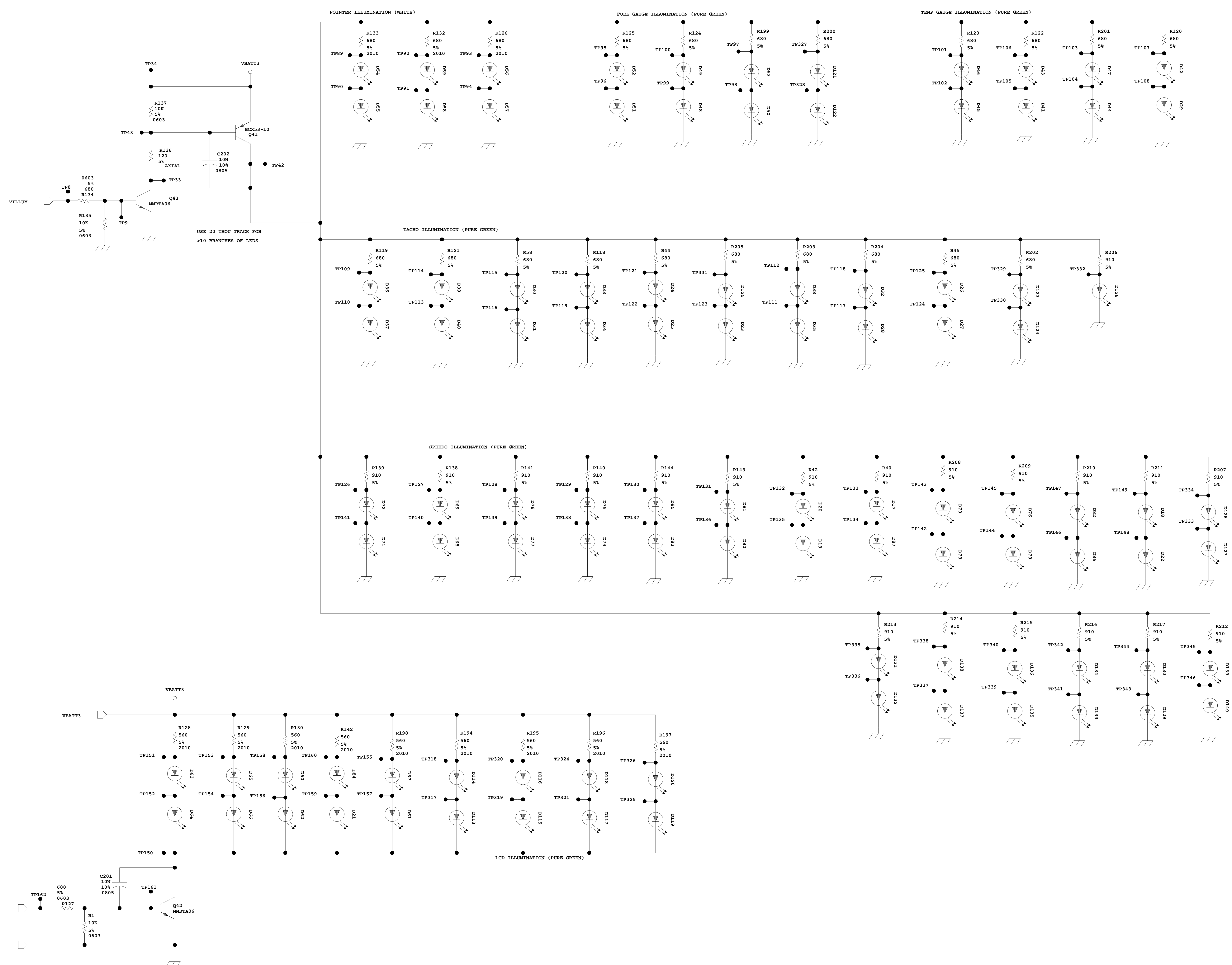

ADD 600 MILLIMETRES SQUARED COPPER HEAT SINK TO TAB OF Q41
ADD 20 MILLIMETRES SQUARED COPPER HEAT SINK TO COLLECTOR OF Q42
ADD 16 MILLIMETRES SQUARED COPPER HEAT SINK TO CATHODE OF EVERY LED

FAST MUST COMPLY WITH SPECIFICATION IEC-60950-1:01 TO HELP SAFEGUARD HEALTH, SAFETY AND THE ENVIRONMENT

Visteon PRODUCT ENGINEERING

COMPUTER MANUAL "E" SIZE

CG COLUMN = GRAPHIC DATA LEVEL ORIGINAL WHEN RED

DO NOT SCALE ABOVE SCALE FOR REFERENCE ONLY

DATE	PROJECT/CHK/ENCH/NAME	CHECKED	SCALE	APPROVED
Y2M0DD			NONE	

UNLESS OTHERWISE SPECIFIED:
DIMENSIONS ARE IN
 INCHES MILLIMETERS

MATCHED DIM. +/- ANGULAR DIM. +/- 3RD ANGLE PROJECTION STAMPED DIM. +/-

MATERIAL: APP: DATE:

NAME: SKETCH - WIRING DIAGRAM (DRAWING_NAME)

NO. MS-XXXX-3458-XX

PWB PLANT CODE:

SCP PHYSICAL LAYER EMC LAYOUT REQUIREMENTS

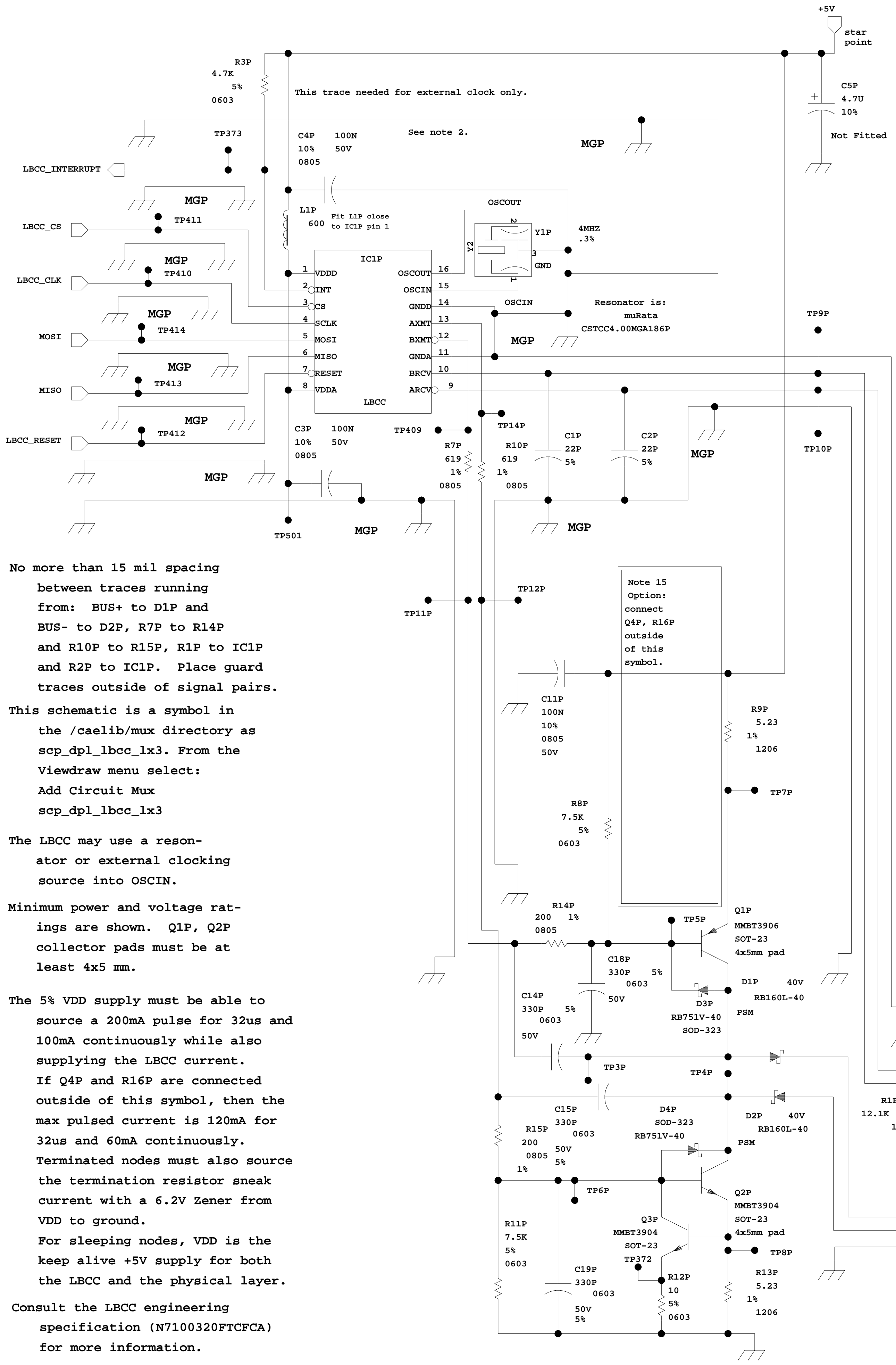

- Place a Microchip Ground Plane (MGP) under IC1P. The MGP exists directly under and on the PCB solder layer of IC1P. Connect GNDA and GNDD to the MGP with at least a 10 mil track. Connect Y1P, C1P, C2P, C3P and C4P to the MGP.
- Denotes a guard track next to a high speed track. Place CS*, SCLK, MOSI, MISO, INT*, and OSCIN (if the LBCC is externally driven) over a ground plane. In addition, place a guard track next to each of these high speed tracks. Connect one end of the guard tracks to the IC1P MGP. Connect the other end of the guard tracks to the host microprocessor MGP. The IC1P MGP and the host microprocessor MGP are the same ground.
- The positive side of C5P is the star point connection for VDD. Run separate traces for IC1P-1 and IC1P-8 to the C5P VDD star point.
- BUS+ and BUS- must be located on adjacent connector pins. Place C16P and C17P within 4mm of the BUS+, BUS- connector pins. Place LBCC away from connector and align LBCC parallel with connector.
- Place R7P, R10P, C1P, C2P, C3P, C4P, and Y1P within 4mm of IC1P. Place IC1P as close as possible to the host microprocessor. Best placement for C3P and C4P is under IC1P MGP with the ground pads connected directly to IC1P MGP. If PWB is component top side only, connect C3P ground pad directly to IC1P-11 and C4P ground pad directly to IC1P-14. Place the tracks between Y1P and IC1P-15,16 on the bottom side to permit a top side direct connection of the C4P ground pad to IC1P-14.
- Place R8P, R9P, R14P, C11P, C14P, C18P and D1P close to Q1P. Place C18P closest to Q1P with a good ground.
- Place R11P, R12P, R13P, R15P, C15P, C19P, D2P and Q3P close to Q2P. Place C19P closest to Q2P with good GND.
- Place R1P and R2P close to Bus+ and Bus- branch points.
- At least 20 mil wide traces required for connecting: BUS+, BUS-, R9P, R13P, C16P, C17P, D1P, D2P, and collector and emitter of Q1P and Q2P.
- Refer to SCP Vehicle Network Implementation requirements (ES-F7LC-12K529-D_) and EESE for termination resistance. Termination power requirement is (24V*24V)/Rbus at rated module temperature. Suggested 360 Ohm resistors are leaded Dale CPF-2s or two 2512 180 Ohms in series.

- No more than 15 mil spacing between traces running from: BUS+ to D1P and BUS- to D2P, R7P to R14P and R10P to R15P, R1P to IC1P and R2P to IC1P. Place guard traces outside of signal pairs.
- This schematic is a symbol in the /caelib/mux directory as scp_dpl_lbcc_lx3. From the Viewdraw menu select: Add Circuit Mux scp_dpl_lbcc_lx3
- The LBCC may use a resonator or external clocking source into OSCIN.
- Minimum power and voltage ratings are shown. Q1P, Q2P collector pads must be at least 4x5 mm.
- The 5% VDD supply must be able to source a 200mA pulse for 32us and 100mA continuously while also supplying the LBCC current. If Q4P and R16P are connected outside of this symbol, then the max pulsed current is 120mA for 32us and 60mA continuously. Terminated nodes must also source the termination resistor sneak current with a 6.2V Zener from VDD to ground. For sleeping nodes, VDD is the keep alive +5V supply for both the LBCC and the physical layer.
- Consult the LBCC engineering specification (N7100320FTCFCA) for more information.
- Run the Host Interface Test for 24 hours error free at rated module temperature extremes.

NO. MS-XXXX-3458-XX										
DATE	LET	REVISIONS			CG	MAN	CK	APP		
4/1/98		Made from Zinger LX3.							PTS	
CSP deleted IC1P pins 1 and 8 short circuited L1P added between C4P and IC1P pin on +5V Instruction added to place L1P close to IC1P pin 1 Change made on recommendation of EMC engineer R. Daniels P. L'Enfant, 12th February 2001										
PART MUST COMPLY WITH SPECIFICATION WSS-M99F9999-A1 TO HELP SAFEGUARD HEALTH, SAFETY AND THE ENVIRONMENT										
Visteon PRODUCT ENGINEERING										
<input checked="" type="checkbox"/> COMPUTER <input type="checkbox"/> MANUAL "D" SIZE CG COLUMN = GRAPHIC DATA LEVEL ORIGINAL WHEN RED ENGLISH 1 2 3 4 5 6 METRIC 20 30 40 50 60 70 80 90 100 110 120 130 140 150 160 DO NOT SCALE ABOVE SCALE FOR REFERENCE ONLY										
REF	PROJECT/SCH/SCH_NAME	DATE	CHECKED	SCALE	APPROVED					
		YYMMDD		NONE						
UNLESS OTHERWISE SPECIFIED: DIMENSIONS ARE IN <input type="checkbox"/> INCHES <input type="checkbox"/> MILLIMETERS MACHINED DIM. +/- 3RD ANGLE PROJECTION ANGULAR DIM. +/- STAMPED DIM. +/-										
MATERIAL					APP					
					DATE					
NAME	SKETCH - WIRING DIAGRAM				(DRAWING_NAME)					
NO. MS-XXXX-3458-XX										
PWB PLANT CODE:										

X355 "SCP" PWB12418 :- SHEET 15

Moved column position pot circuits from column FUB to interface FUB
P. L. Infant, 11th December 2000

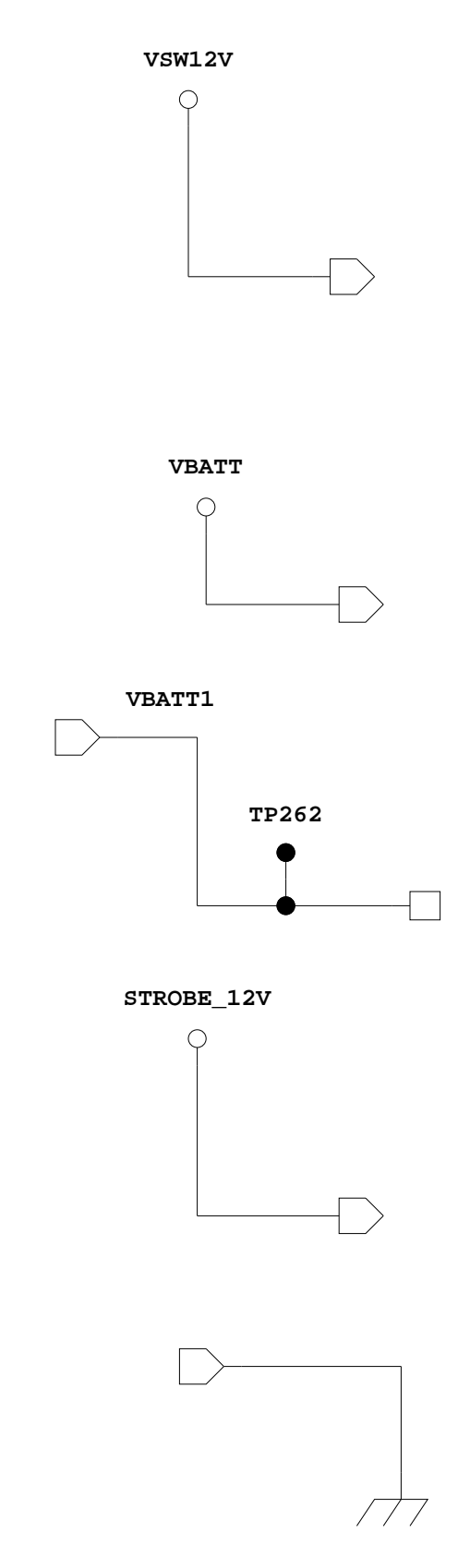
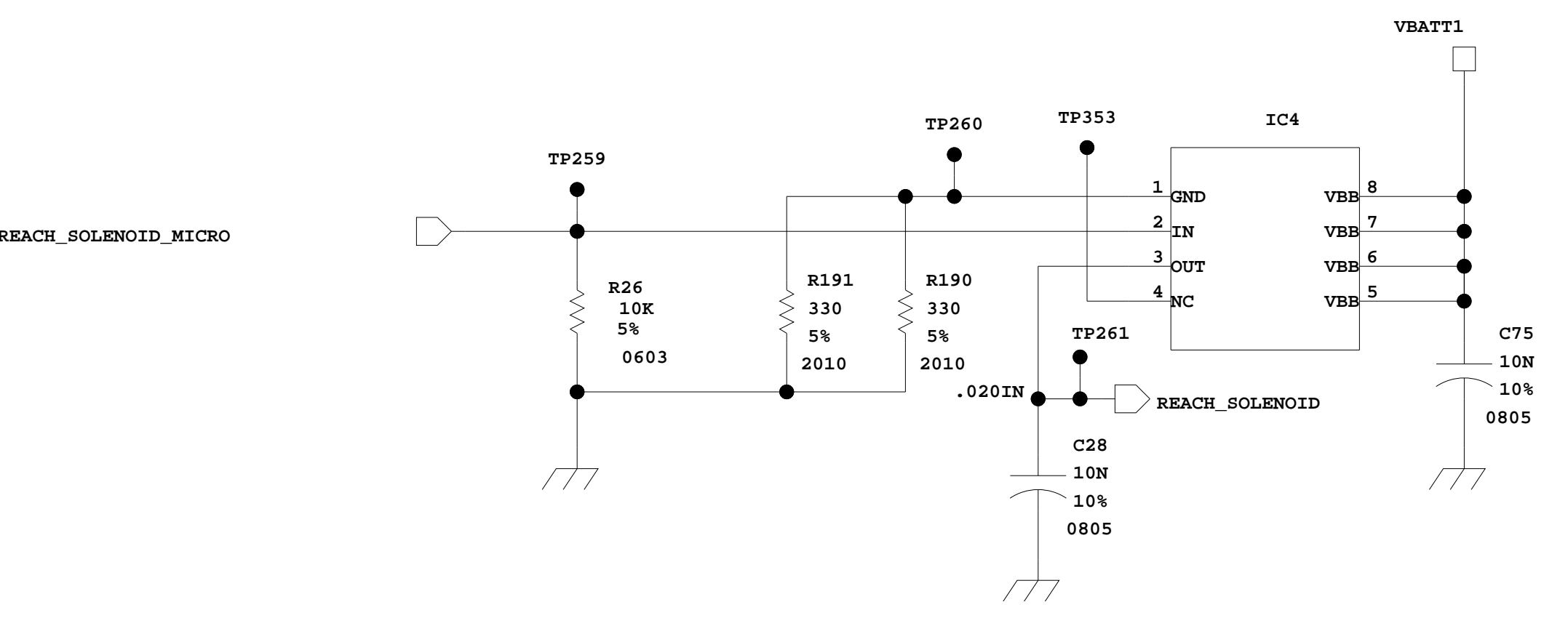
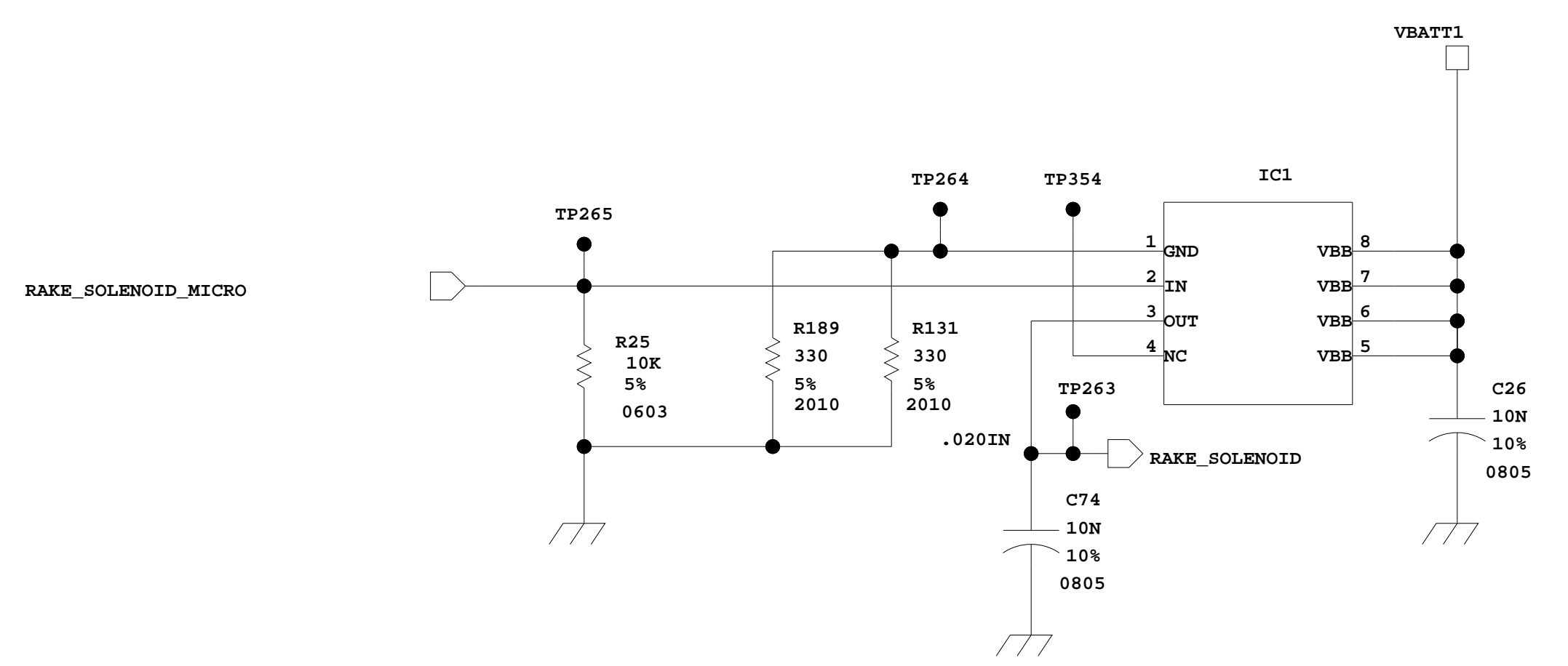
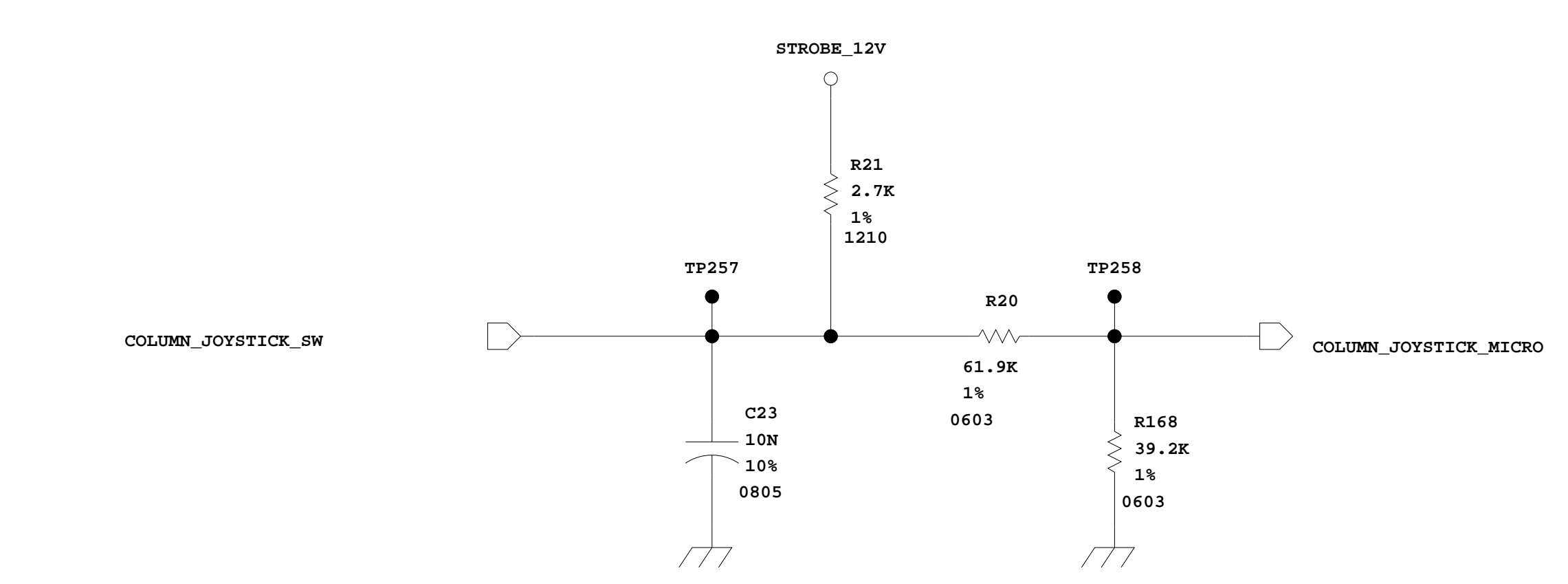
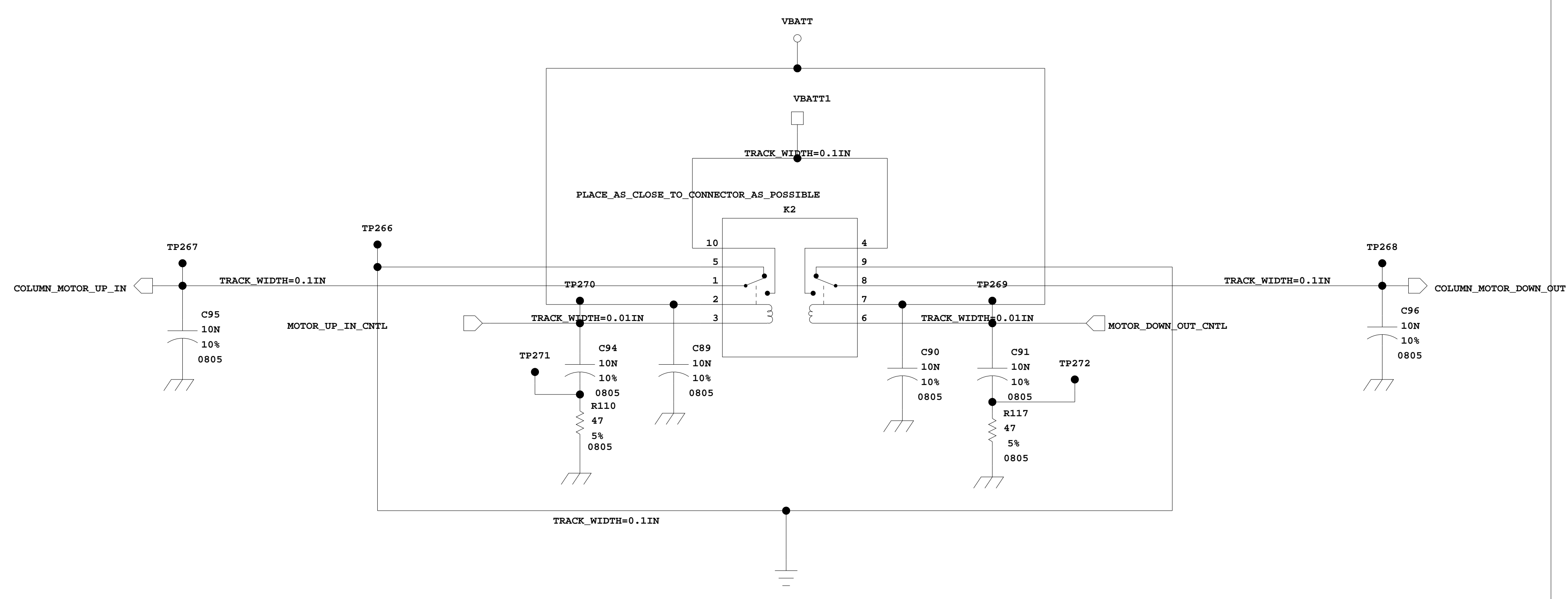
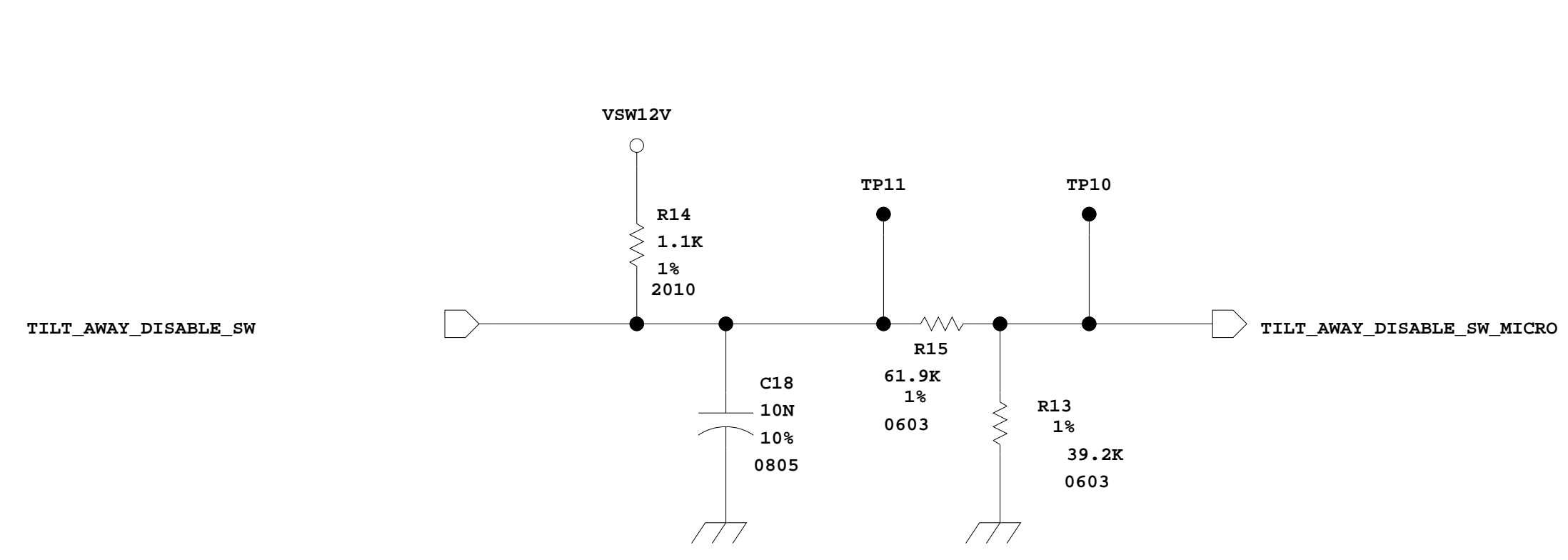

PART MUST COMPLY WITH SPECIFICATION WS-893999-A1 TO HELP SAFEGUARD HEALTH, SAFETY AND THE ENVIRONMENT

Visteon PRODUCT ENGINEERING

COMPUTER MANUAL "E" SIZE

CG COLUMN = GRAPHIC DATA LEVEL ORIGINAL WHEN RED

DO NOT SCALE ABOVE SCALE FOR REFERENCE ONLY

REF	PROJECT/CHK/SCH NAME	DATE	CHECKED	SCALE	APPROVED
		YYMMDD		NONE	

UNLESS OTHERWISE SPECIFIED:
 DIMENSIONS ARE IN:
 INCHES MILLIMETERS
 MACHINED DIM. +/- 3RD ANGLE PROJECTION
 ANGULAR DIM. +/- STAMPED DIM. +/-

MATERIAL: _____ APP: _____
 DATE: _____

NAME: SKETCH - WIRING DIAGRAM (DRAWING_NAME)

NO. MS-XXXX-3458-XX

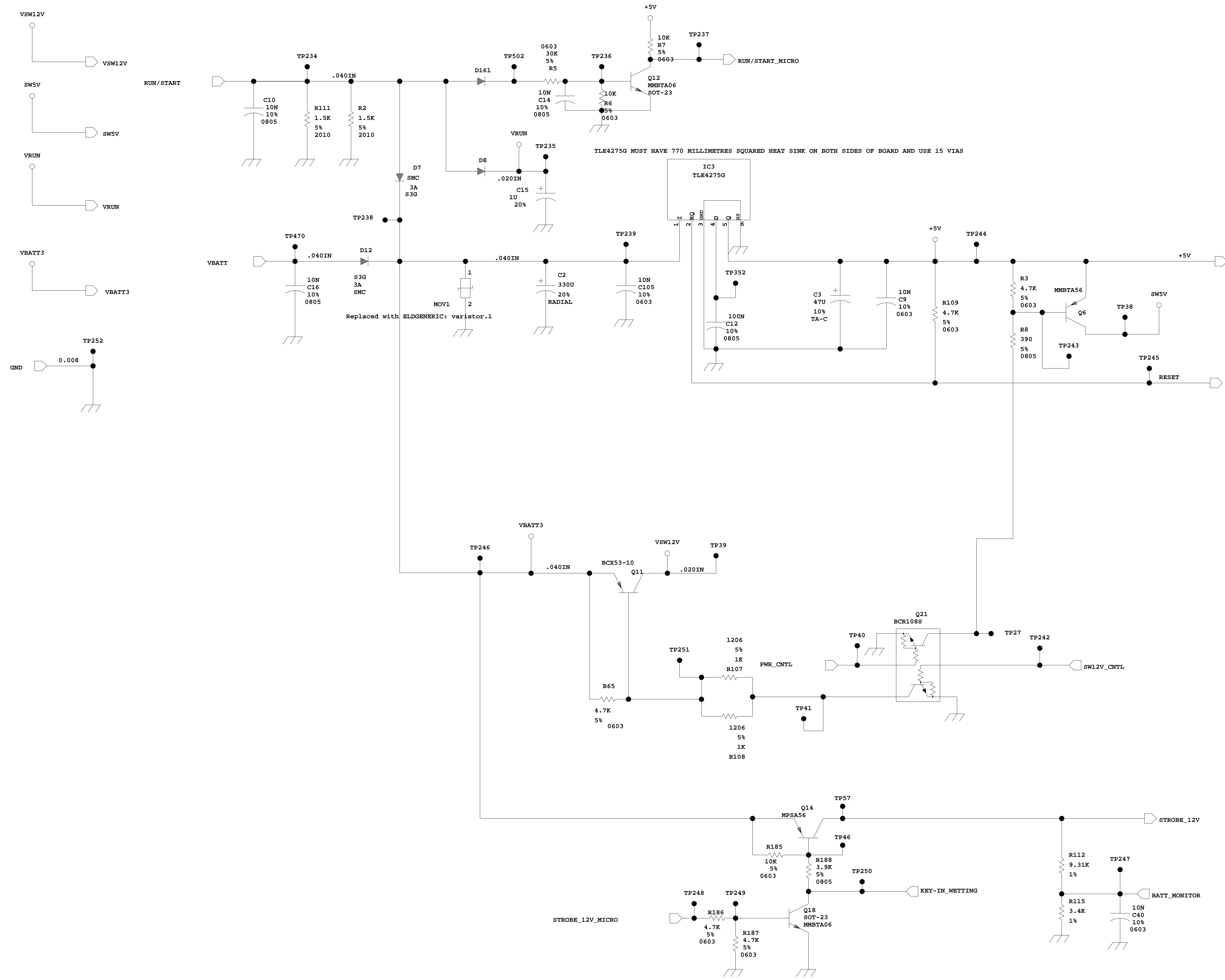

NO. MS-XXXX-3458-XX						
DATE	LET	REVISIONS	CG	MAN	CK	APP
		Added key-in wetting control to STROBE_12V				
		P. L'Enfant, 20th October 2000				
		Changed 1A diodes to GF1G				
		P. L'Enfant, 25th October 2000				
		Moved battery monitor circuit from VBATT3 to STROBE_12V				
		Changed C3 from 68u to 47u				
		P. L'Enfant, 19th December 2000				
		Added D161 to RUN/START circuit to prevent any feedback on circuits using VRUN for power causing incorrect ignition key position decoding				
		P. L'Enfant, 30th January 2001				
		C15 changed to 1UF				
		R115 package change				
		R112 package change				
		Mark Lansley May 2001				
		D8, D161 Diode change				
		Mark Lansley June 2001				

PART MUST COMPLY WITH SPECIFICATION WSS-M999999-1A TO HELP SAFEGUARD HEALTH, SAFETY AND THE ENVIRONMENT

Visteon PRODUCT ENGINEERING

COMPUTER MANUAL "D" SIZE

CG COLUMN = GRAPHIC DATA LEVEL ORIGINAL WHEN RED

ENGLISH 1 2 3 4 5 6
METRIC 20 30 40 50 60 70 80 90 100 110 120 130 140 150 160

DO NOT SCALE ABOVE SCALE FOR REFERENCE ONLY

REF	PROJECT/SCH/SCR_NAME
DRAWN BY	DATE
CHECKED	SCALE
YMMDD	NONE
APPROVED	

UNLESS OTHERWISE SPECIFIED:
 DIMENSIONS ARE IN INCHES
 DIMENSIONS ARE IN MILLIMETERS
 MACHINED DIM. +/-
 ANGULAR DIM. +/-

3RD ANGLE PROJECTION
 STAMPED DIM. +/-

MATERIAL	APP
	DATE

NAME SKETCH - WIRING DIAGRAM
 POWER SUPPLY

NO. MS-XXXX-3458-XX

PWB PLANT CODE:

X355 "POWER SUPPLY" PWB12418 :- SHEET 2

X350: FLASH PROGRAMMING

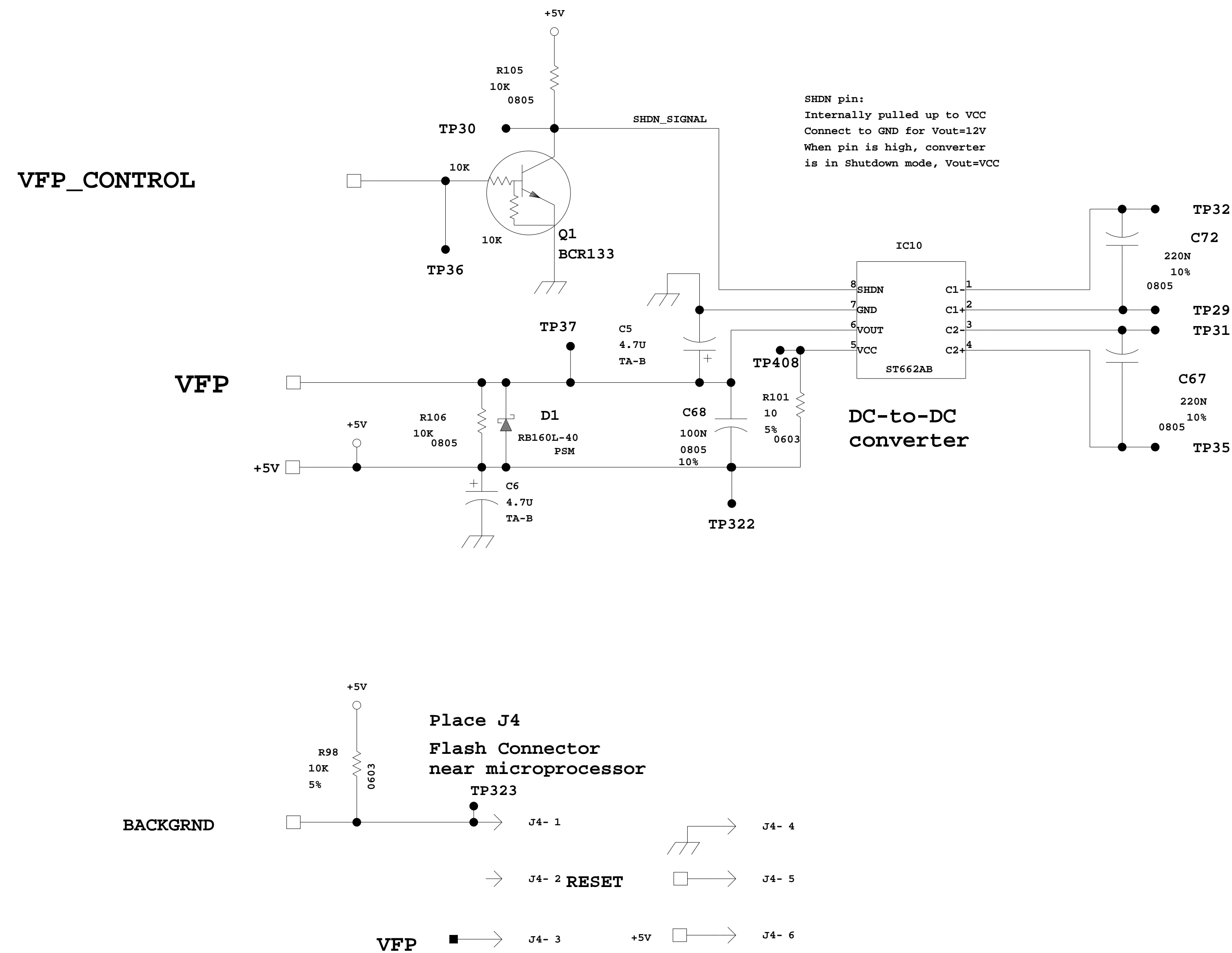

NO.		MS-XXXX-3458-XX				
DATE	LET	REVISIONS	CG	MAN	CK	APP
		0.5micron Micro Update Depopulate all Flash components except for R98 (required for debug) P.Wood, 10th July 2003				

PART MUST COMPLY WITH SPECIFICATION WSS-M99F9999-A1
TO HELP SAFEGUARD HEALTH, SAFETY AND THE ENVIRONMENT

Visteon PRODUCT ENGINEERING

COMPUTER MANUAL "D" SIZE

CG COLUMN = GRAPHIC DATA LEVEL ORIGINAL WHEN RED

ENGLISH 1 2 3 4 5 6
METRIC 20 30 40 50 60 70 80 90 100 110 120 130 140 150 160

DO NOT SCALE ABOVE SCALE FOR REFERENCE ONLY

REF	PROJECT/SCH/SCH_NAME

DRAWN BY	DATE	CHECKED	SCALE	APPROVED
			NONE	

UNLESS OTHERWISE SPECIFIED:
DIMENSIONS ARE IN
 INCHES MILLIMETERS
MACHINED DIM. +/-
ANGULAR DIM. +/-

3RD ANGLE PROJECTION
STAMPED DIM. +/-

MATERIAL	APP
	DATE

NAME SKETCH - WIRING DIAGRAM
(DRAWING_NAME)

NO. MS-XXXX-3458-XX

DATE	LET	REVISIONS	CU	MAN	CK	APP
		Changed AUTOLAMP_SENSOR_MICRO to a digital input. Added BRAKE_PAD_WEAR_MICRO as an analog input.				
		P. Wood, July 2003				

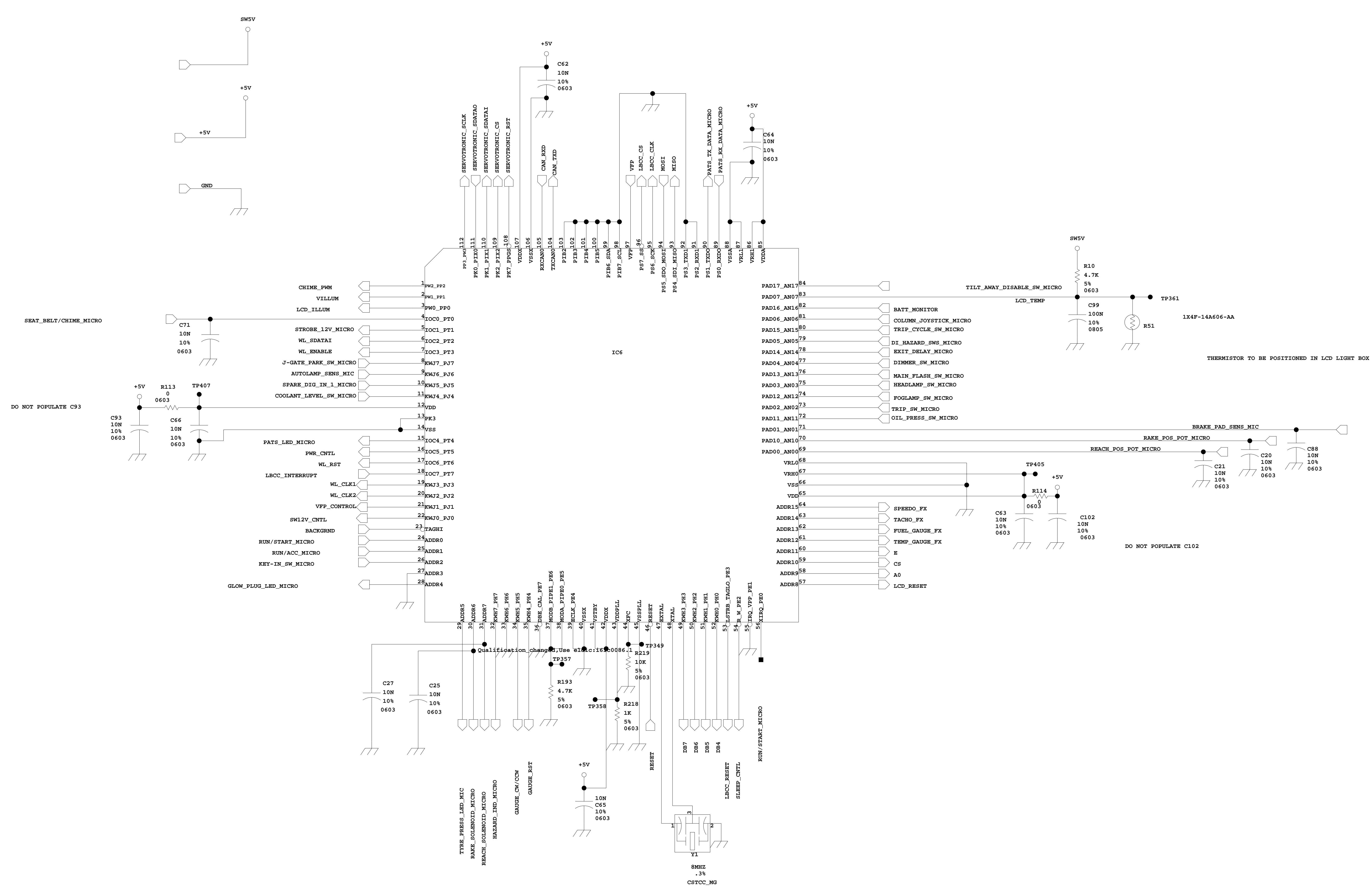

FAST MUST COMPLY WITH SPECIFICATION MS-8999999-A1 TO HELP SAFEGUARD HEALTH, SAFETY AND THE ENVIRONMENT

Visteon PRODUCT ENGINEERING

COMPUTER [X] MANUAL [] 1/8" SIZE

CU COLUMN = GRAPHIC DATA LEVEL ORIGINAL WHEN RED

ENGINEERING SCALE: 0 1 2 3 4 5 6

DO NOT SCALE ABOVE SCALE FOR REFERENCE ONLY

REF	PROJECT/SCN/CHK_NAME	SCALE	APPROVED

UNLESS OTHERWISE SPECIFIED:
 DIMENSIONS ARE IN: [] INCHES [X] MILLIMETERS
 MACHINED DIM. +/- ANGULAR DIM. +/-
 3RD ANGLE PROJECTION
 STAMPED DIM. +/-

MATERIAL: _____ APP: _____ DATE: _____

NAME: SKETCH - WIRING DIAGRAM (DRAWING_NAME)

NO. MS-XXXX-3458-XX

PWB PLANT CODE: _____

3355 "MICRO" PWB12418 SHEET 3

NO. MS-XXXX-3458-XX

DATE	LET	REVISIONS	CG	MAN	CK	APP
		Diode D301 added to prevent J-Gate Park input voltage feeding in during park condition Mark Lansley 04/05/01				
		D301 Diode change Mark Lansley June 2001				
		X355 Update Moved Autolamp circuit onto SPARE_DIGITAL_IN_2 circuit. Replaced original Autolamp circuit with brake pad wear circuit. P.Wood, July 2003				
		X355 Update Added R310, the BRAKE_PAD_WEAR_OFFSET_RESISTOR (moved from Sheet 1) P.Wood, Sept 2003				

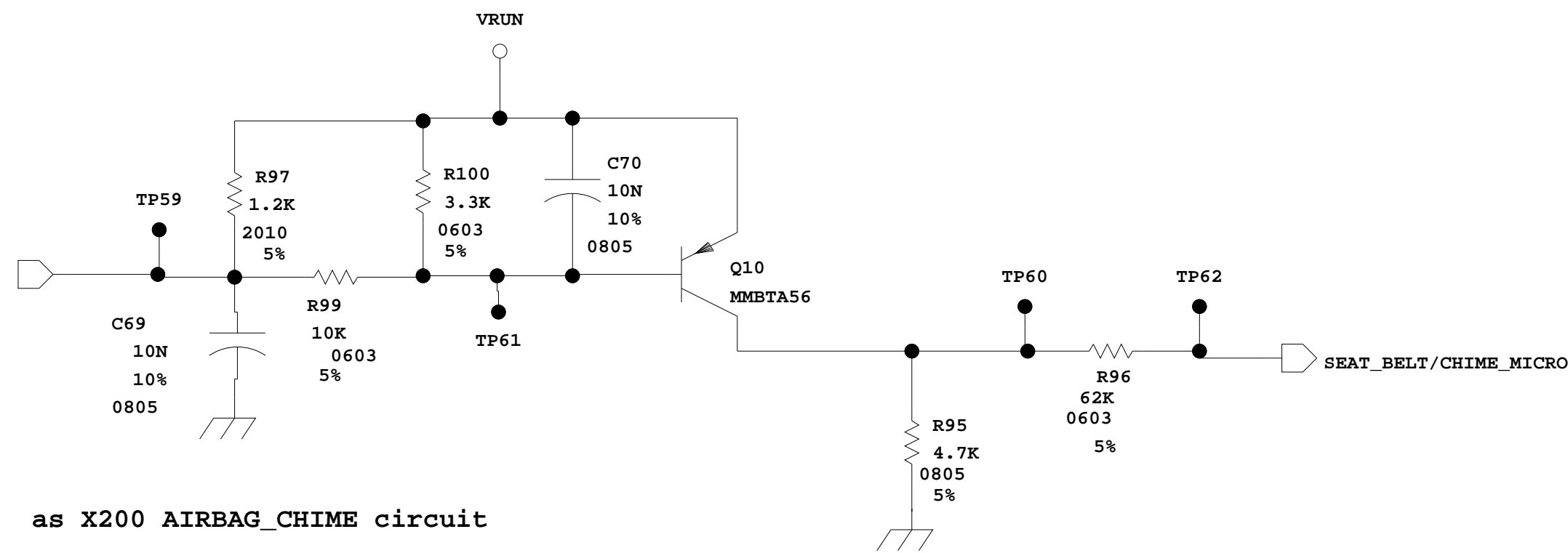
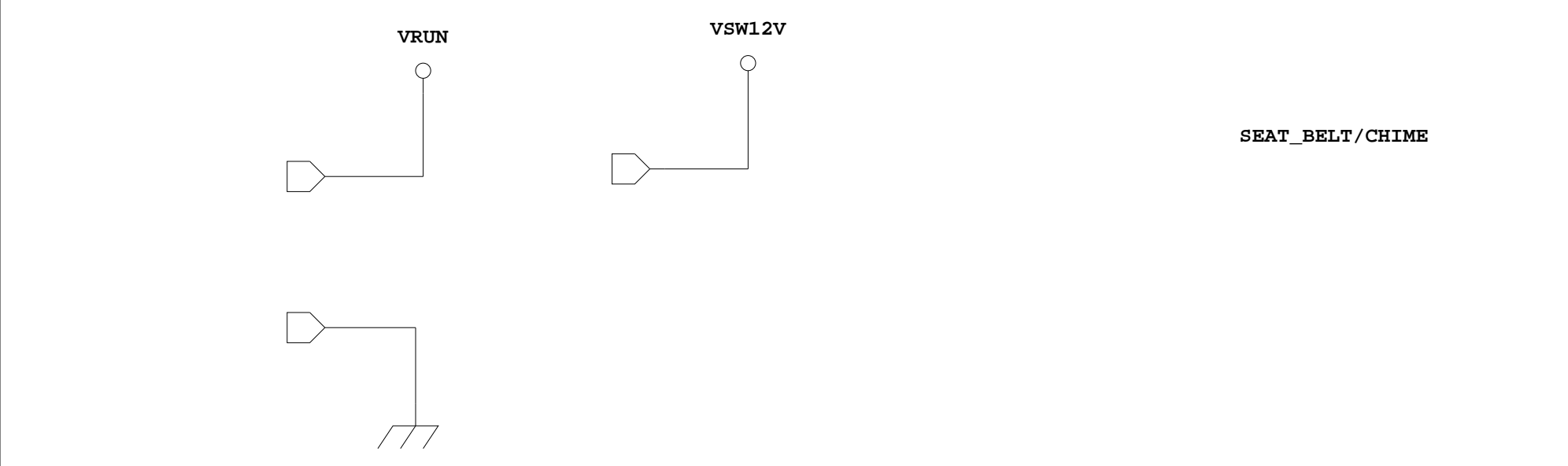
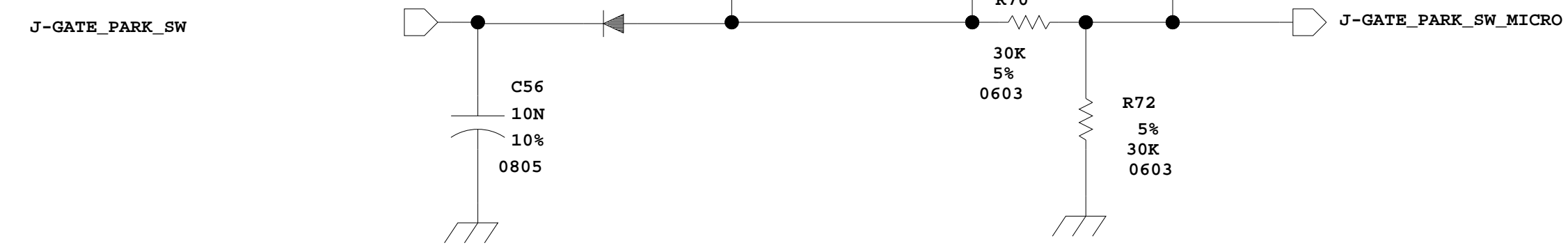
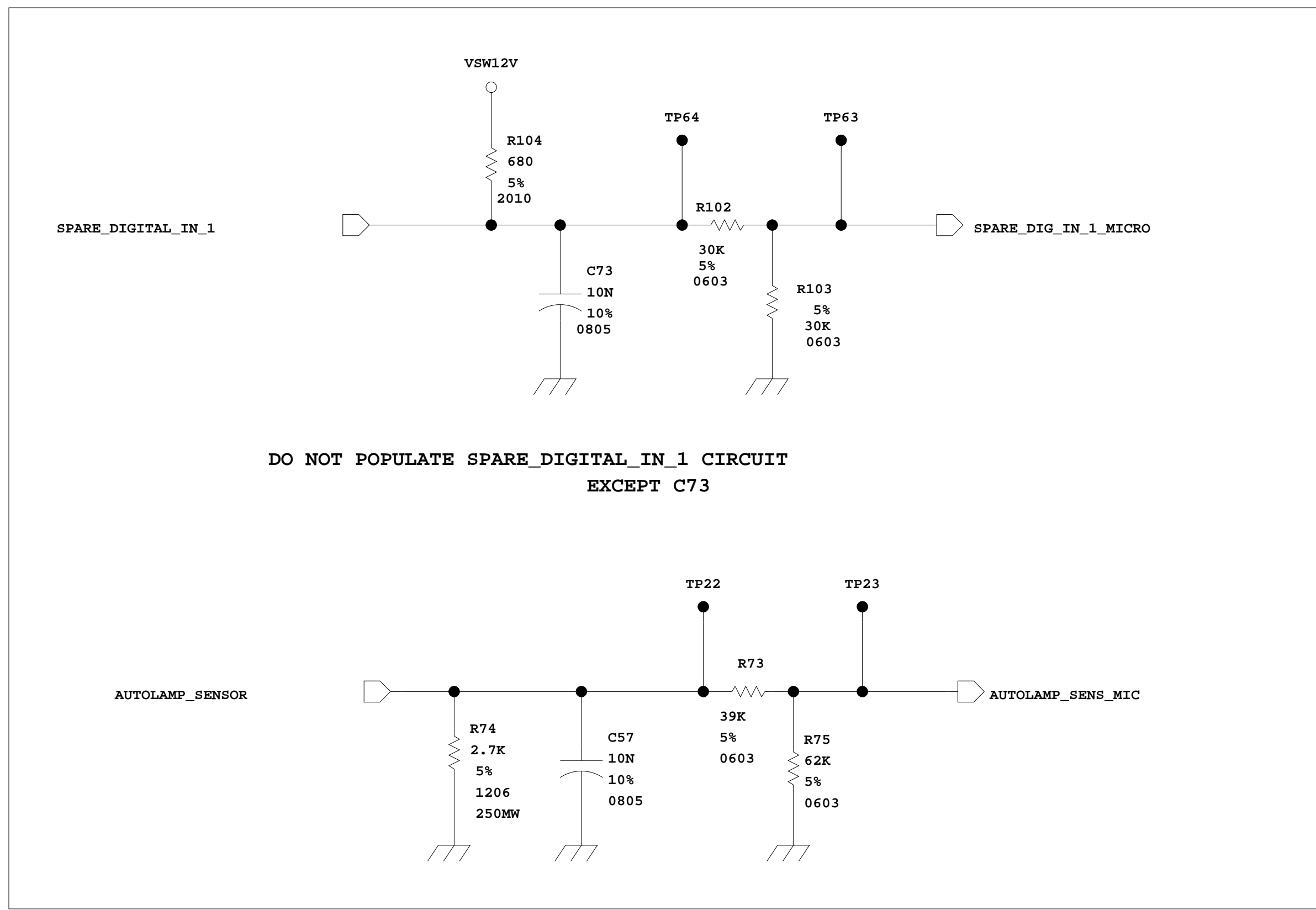
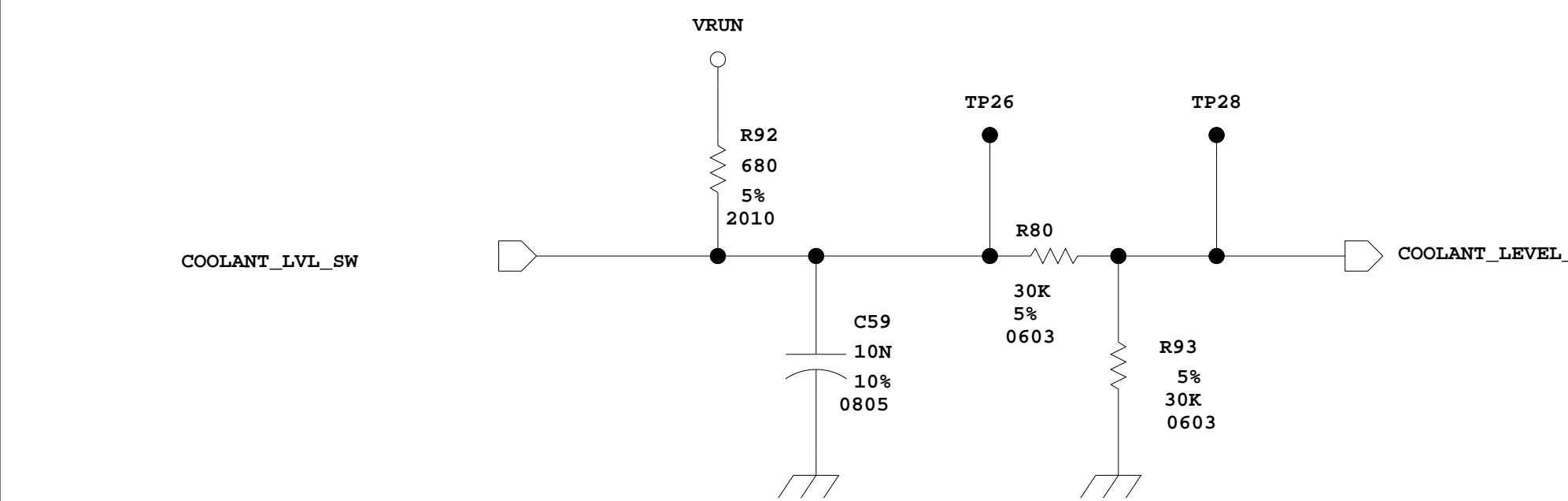
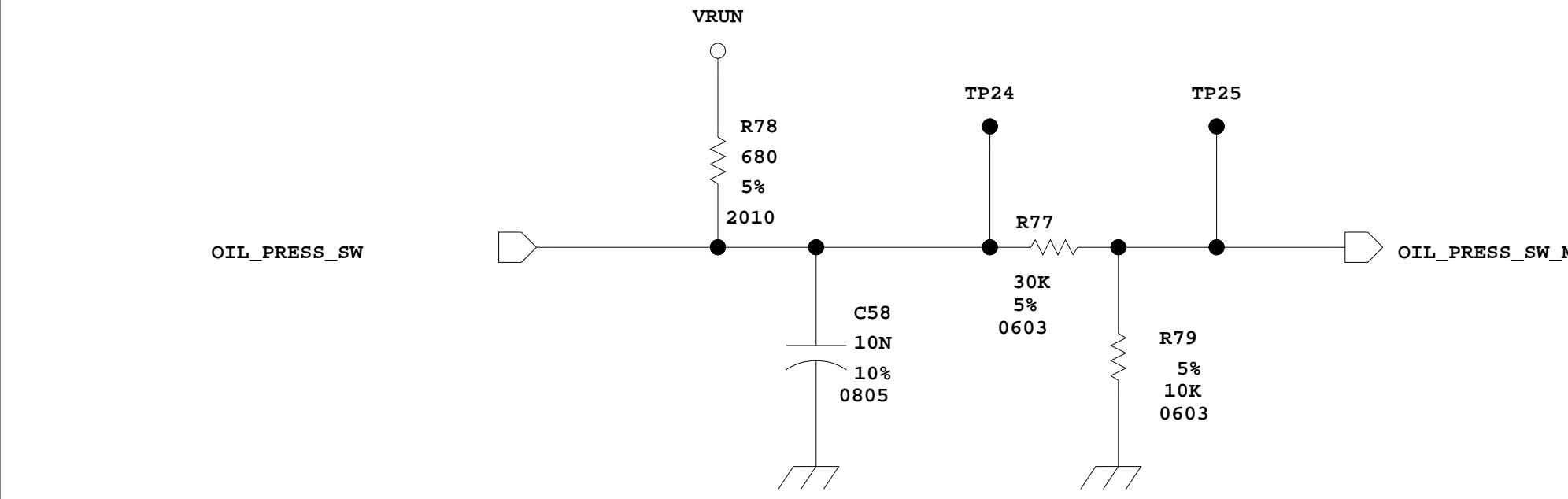
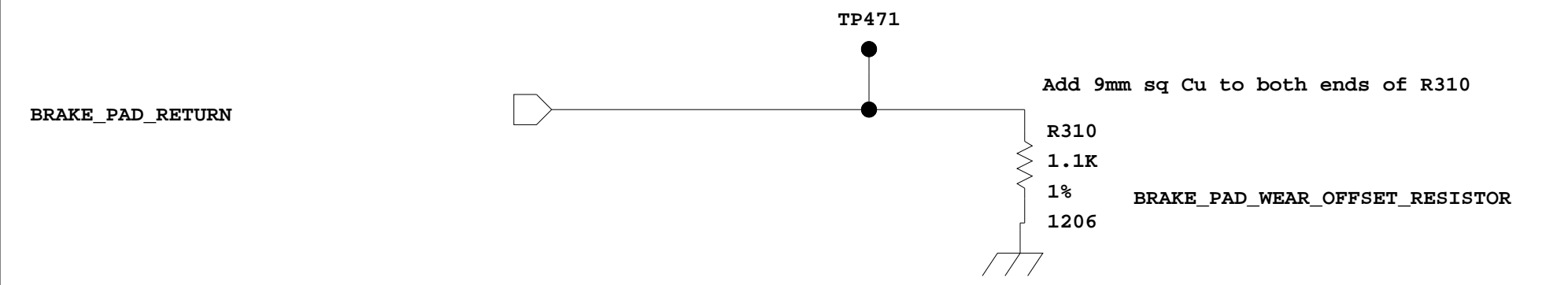
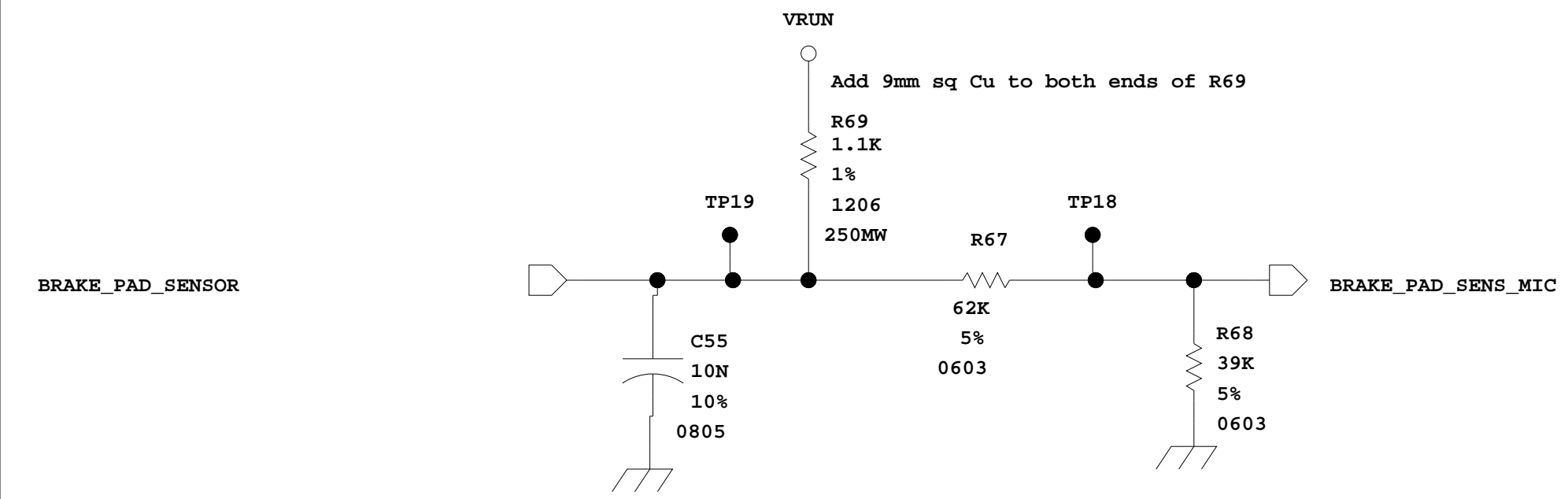

as X200 AIRBAG_CHIME circuit

PART MUST COMPLY WITH SPECIFICATION WSS-M99F9999-A1 TO HELP SAFEGUARD HEALTH, SAFETY AND THE ENVIRONMENT

Visteon PRODUCT ENGINEERING

COMPUTER MANUAL "D" SIZE

CG COLUMN = GRAPHIC DATA LEVEL ORIGINAL WHEN RED

ENGLISH 1 2 3 4 5 6
METRIC 20 30 40 50 60 70 80 90 100 110 120 130 140 150 160

DO NOT SCALE ABOVE SCALE FOR REFERENCE ONLY

REF	PROJECT/SCH/SCH_NAME
DRAWN BY	DATE
CHECKED	SCALE
YYMMDD	NONE
APPROVED	

UNLESS OTHERWISE SPECIFIED:
DIMENSIONS ARE IN INCHES MILLIMETERS
MACHINED DIM. +/- ANGULAR DIM. +/-

3RD ANGLE PROJECTION STAMPED DIM. +/-

MATERIAL	APP
	DATE

NAME SKETCH - WIRING DIAGRAM (DRAWING_NAME)

NO. MS-XXXX-3458-XX

X355 "MISCELL INPUTS" PWB12418 :- SHEET 9

DATE	LET	REVISIONS	CU	MAN	CK	APP

Changed supplies for MC_GENERAL_YELLOW&RED warning lights to VBATT3 instead of VRUN.
 Changed SPARE_LED_MICRO circuits to GLOW_PLUG_LED_MICRO and TYRE_PRESS_LED_MICRO circuits.
 P. Wood, July 2003

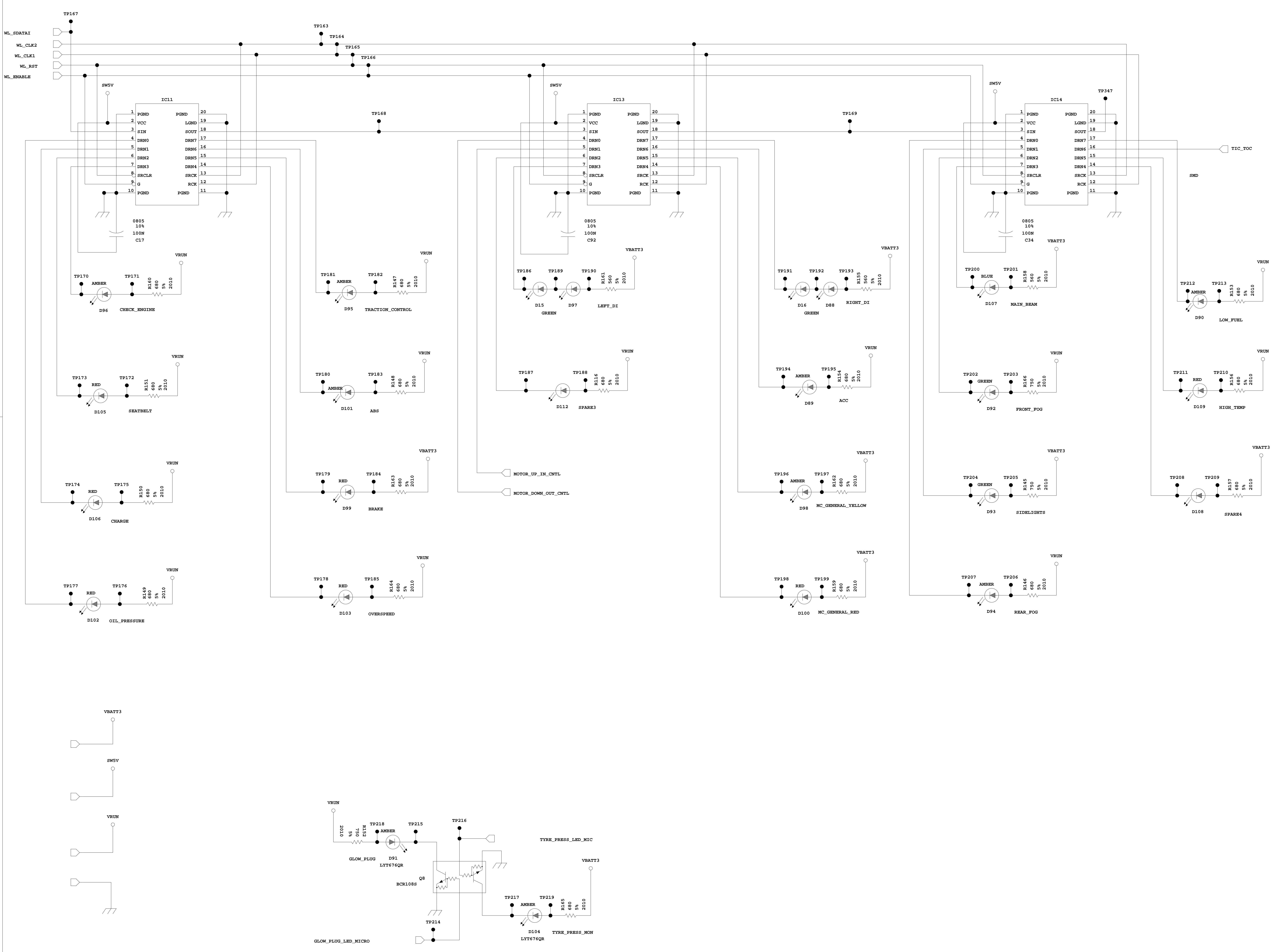

PART MUST COMPLY WITH SPECIFICATION MS-MS99999-A1 TO HELP SAFEGUARD HEALTH, SAFETY AND THE ENVIRONMENT

Visteon PRODUCT ENGINEERING

COMPUTER MANUAL **"E"** SIZE

CU COLUMN - GRAPHIC DATA LEVEL ORIGINAL WHEN RED

ENGLISH 01 10 20 30 40 50 60 70 80 90 100 110 120 130 140 150 160

DO NOT SCALE ABOVE SCALE FOR REFERENCE ONLY

REF	PROJECT/SCH/SCH_NAME	DATE	CHECKED	SCALE	APPROVED
		YYMMDD		NONE	

UNLESS OTHERWISE SPECIFIED:
 DIMENSIONS ARE IN:
 INCHES MILLIMETERS 3RD ANGLE PROJECTION
 MACHINED DIM. +/- ANGULAR DIM. +/- STAMPED DIM. +/-

MATERIAL APP DATE

NAME SKETCH - WIRING DIAGRAM (DRAWING_NAME)

NO. MS-XXXX-3458-XX